

**CALIFORNIA
CHAMPIONSHIP**
FRI. AUG. 30th, 2024

136-RANCH SR HORSE
137-RANCH SEL AMA
138-RANCH AMA

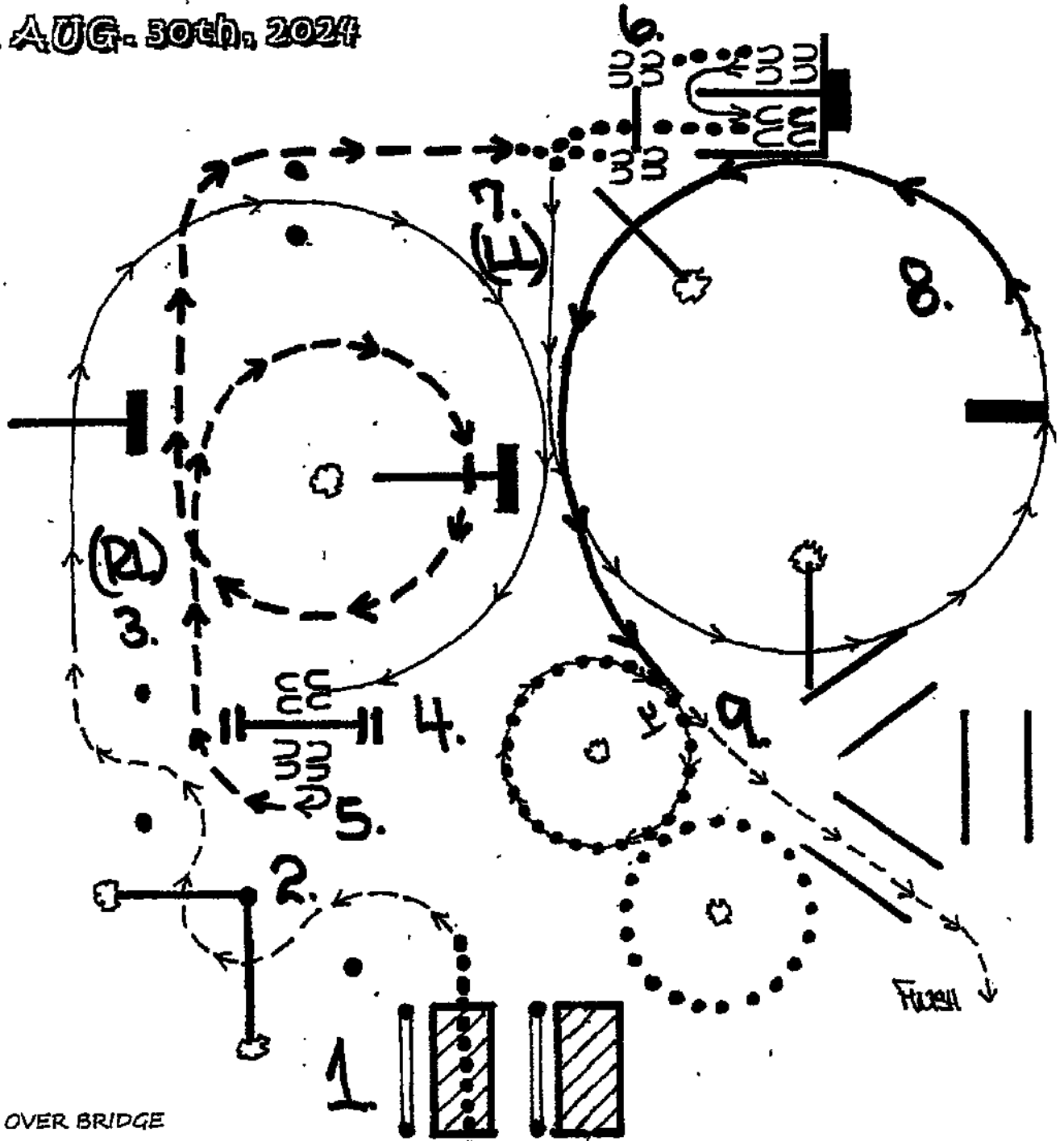

1. WALK OVER BRIDGE
2. JOG THRU SERPENTINE & OVER POLES
3. LOPE OVER POLE (RL) TO GATE
4. GATE:(LH) PUSH THRU CLOSE
5. 1/2 TURN RIGHT, EXTENDED TROT OVER POLE TO SIDE PASS
6. SIDE PASS LEFT OVER POLE WALK INTO CHUTE BACK INTO SECOND CHUTE
7. WALK OUT OVER POLE, LOPE (LL) OVER POLE & JUMP
8. EXTENDED LOPE (LL) & OVER POLE TO DRAG
9. PICK UP ROPE WORK DRAG TO THE RIGHT (WALK/TROT) AROUND MARKER HANG UP ROPE & TROT AWAY

CALIFORNIA CHAMPIONSHIP

FRI. AUG. 30th, 2024

- 139-RANCH-YTH
- 140-RANCH-JR.HORSE
- 141-RANCH-OPEN L-1
- 142-RANCH-AMA L-1
- 143-RANCH-YTH L-1

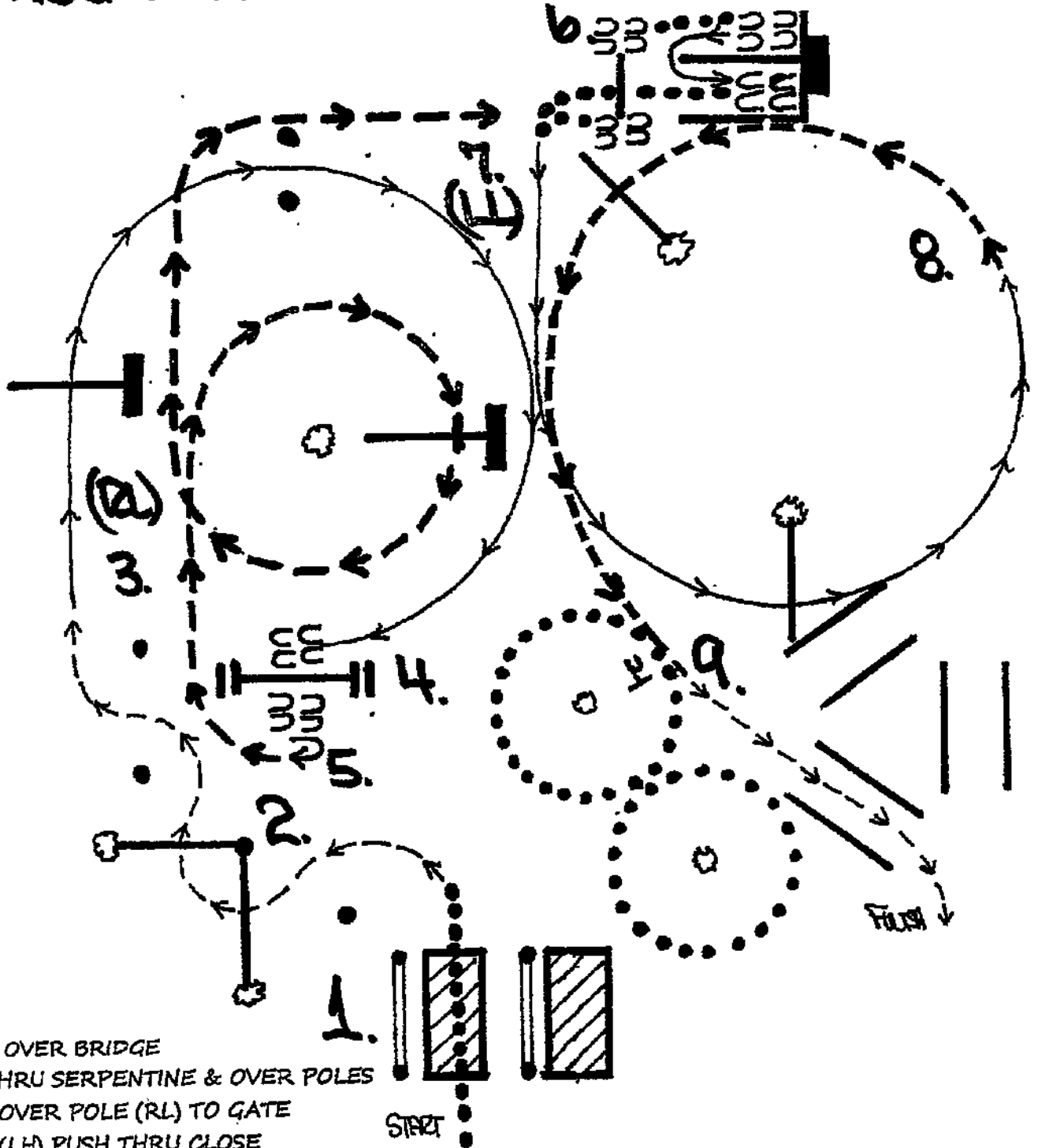

1. WALK OVER BRIDGE
2. JOG THRU SERPENTINE & OVER POLES
3. LOPE OVER POLE (RL) TO GATE
4. GATE:(LH) PUSH THRU CLOSE
5. 1/2 TURN RIGHT, EXTENDED TROT OVER POLE TO SIDE PASS
6. SIDE PASS LEFT OVER POLE WALK INTO CHUTE BACK INTO SECOND CHUTE
7. WALK OUT OVER POLE, LOPE (LL) OVER POLE
8. EXTENDED LOPE (LL) & OVER POLE TO DRAG
9. PICK UP COAT, WALK OR TROT AROUND MARKER, HANG UP COAT TROT AWAY

**CALIFORNIA
CHAMPIONSHIP
FRI. AUG. 30th, 2024**

144-ALL BREED RANCH-11 & UND
WALK/TROT

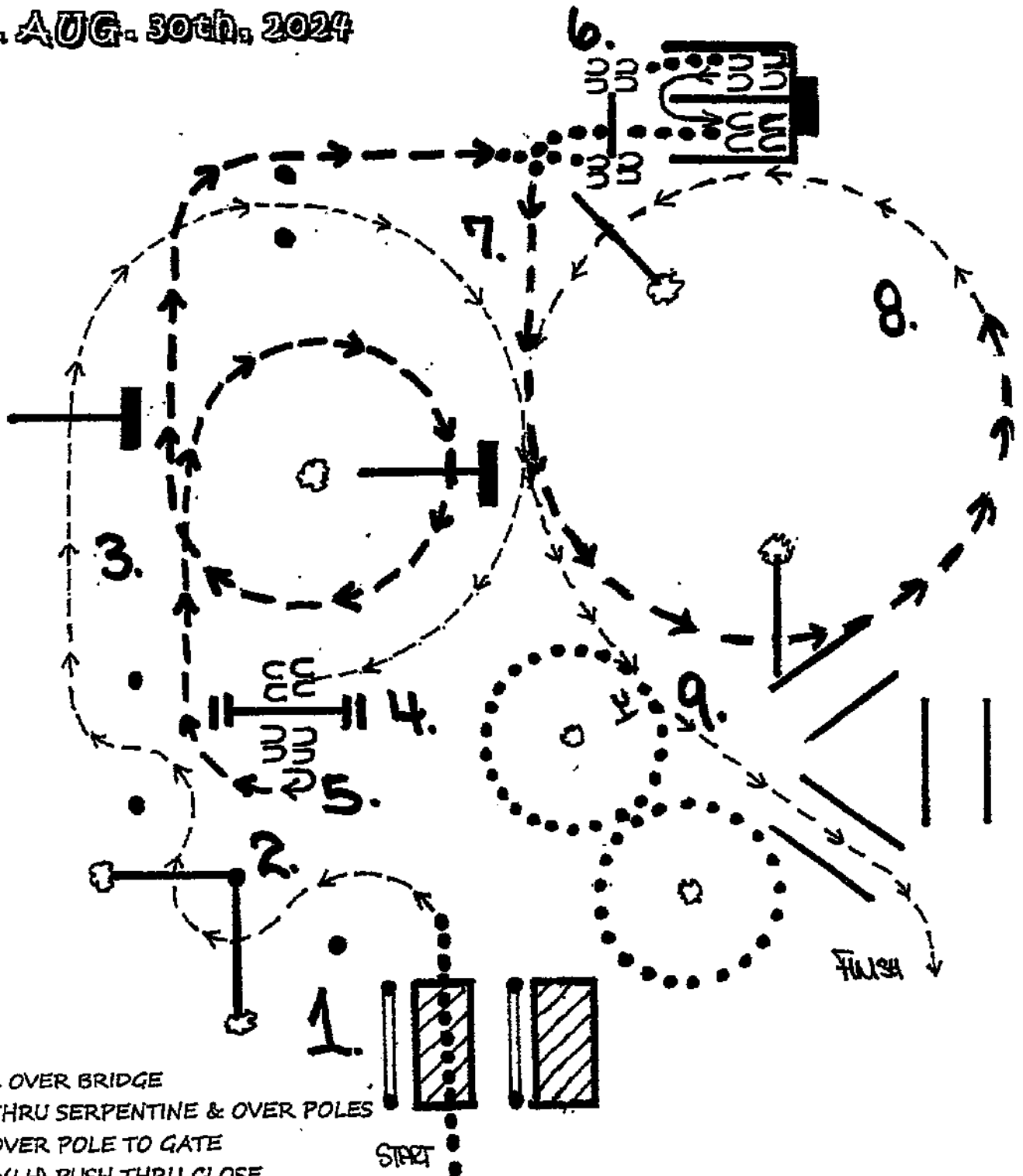

1. WALK OVER BRIDGE
2. JOG THRU SERPENTINE & OVER POLES
3. JOG OVER POLE TO GATE
4. GATE:(LH) PUSH THRU CLOSE
5. 1/2 TURN RIGHT, EXTENDED TROT OVER POLE TO SIDE PASS
6. SIDE PASS LEFT OVER POLE WALK INTO CHUTE BACK INTO SECOND CHUTE
7. WALK OUT OVER POLE, EXTENDED TROT OVER POLE
8. REGULAR TROT OVER POLE TO DRAG
9. PICK UP BUCKET, WALK OR TROT AROUND MARKER, HANG UP BUCKET TROT AWAY

CALIFORNIA CHAMPIONSHIP

SAT. AUG. 31ST, 2024

417-SR HORSE
418-SELECT AMA
419-AMATEUR
420-YOUTH

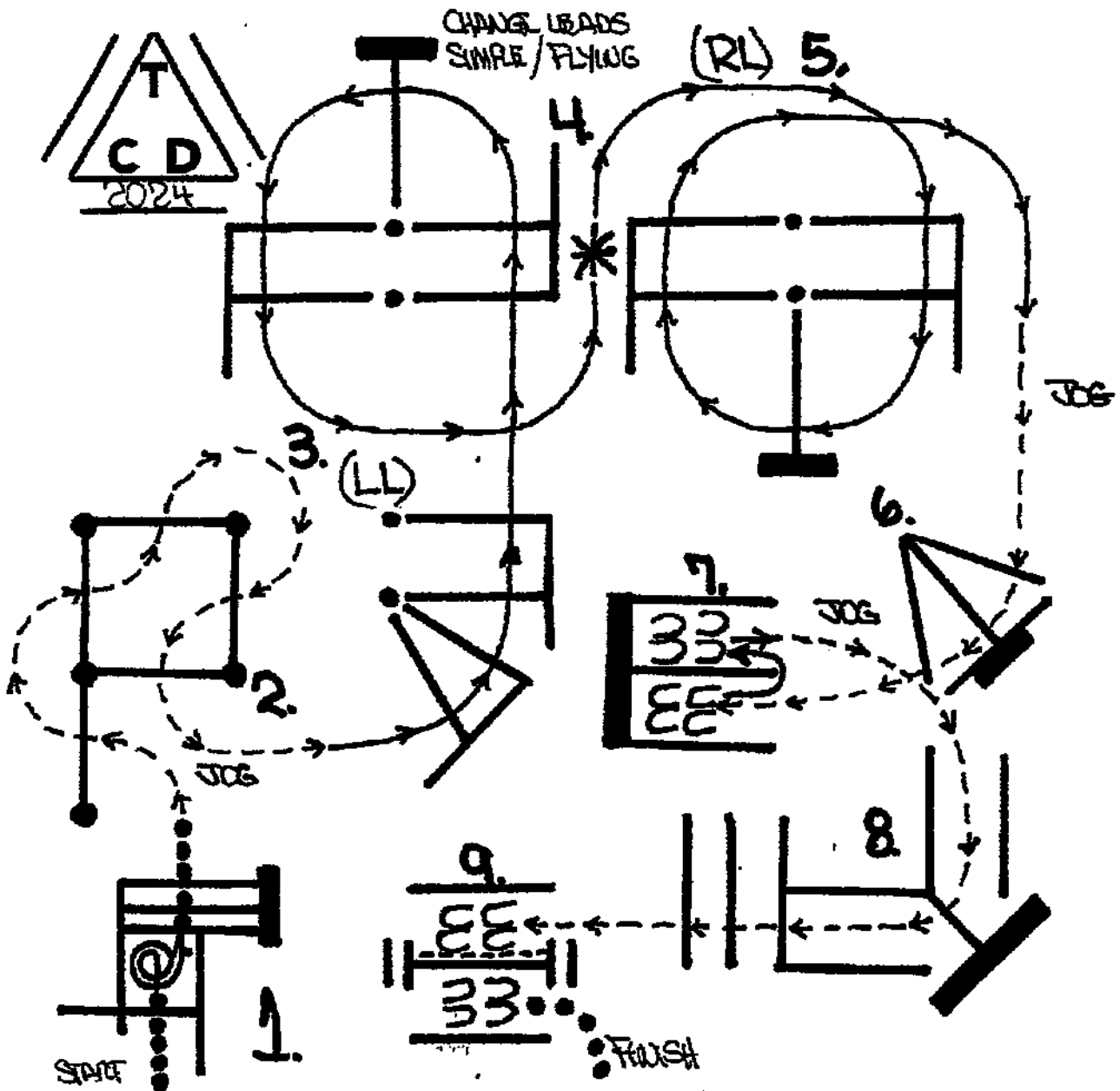

1. WALK INTO BOX 1 1/2 TURNS LEFT, WALK OUT OVER POLES
2. JOG THRU SERPENTINE & OVER POLES
3. LOPE OVER POLES (LL)
4. CHANGE LEADS (SIMPLE/FLYING)
5. LOPE OVER POLES (RL)
6. JOG OVER POLES & INTO CHUTE
7. BACK CHUTE TO CHUTE
8. JOG OUT OF CHUTE, THRU CHUTE & OVER POLES TO GATE
9. GATE:(LH) RIDE THRU OVER POLE CLOSE

CALIFORNIA CHAMPIONSHIP

SAT. AUG. 31st, 2024

421-OPEN L-1
422-YTH L-1
423-AMA L-1
424-JR HORSE
700-NSBA 3/4 YR OLD TRAIL OPEN

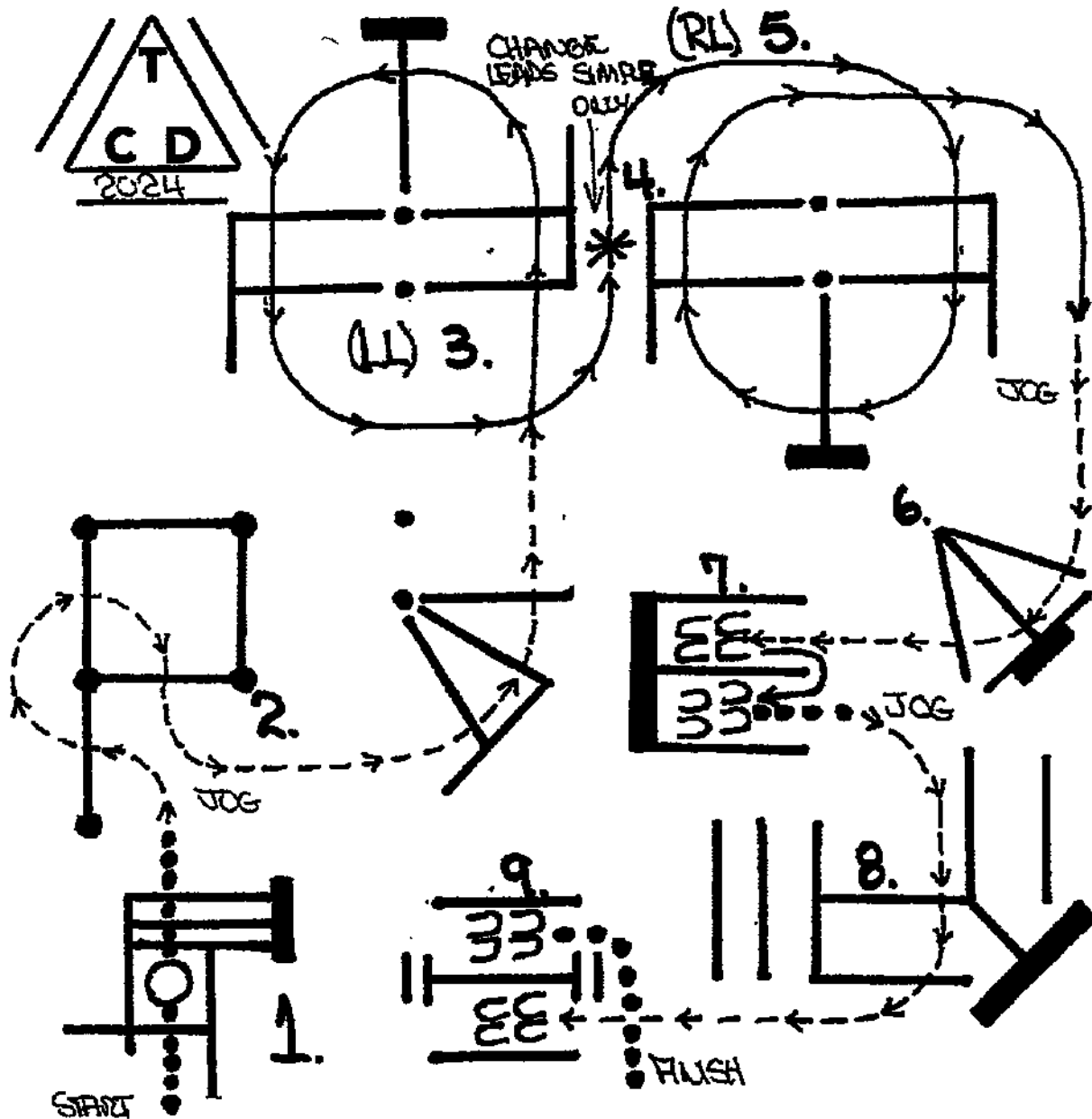

1. WALK INTO BOX 360 EITHER WAY, WALK OUT OVER POLES
2. JOG THRU SERPENTINE & OVER POLES
3. LOPE OVER POLES (LL)
4. CHANGE LEADS (SIMPLE ONLY)
5. LOPE OVER POLES (RL)
6. JOG OVER POLES & INTO CHUTE
7. BACK CHUTE TO CHUTE, WALK OUT
8. JOG OVER POLES TO GATE
9. GATE:(RH) RIDE THRU CLOSE

CALIFORNIA CHAMPIONSHIP

SAT. AUG. 31st, 2024

425-WALK/TROT YTH L-1
426-WALK/TROT AMA L-1

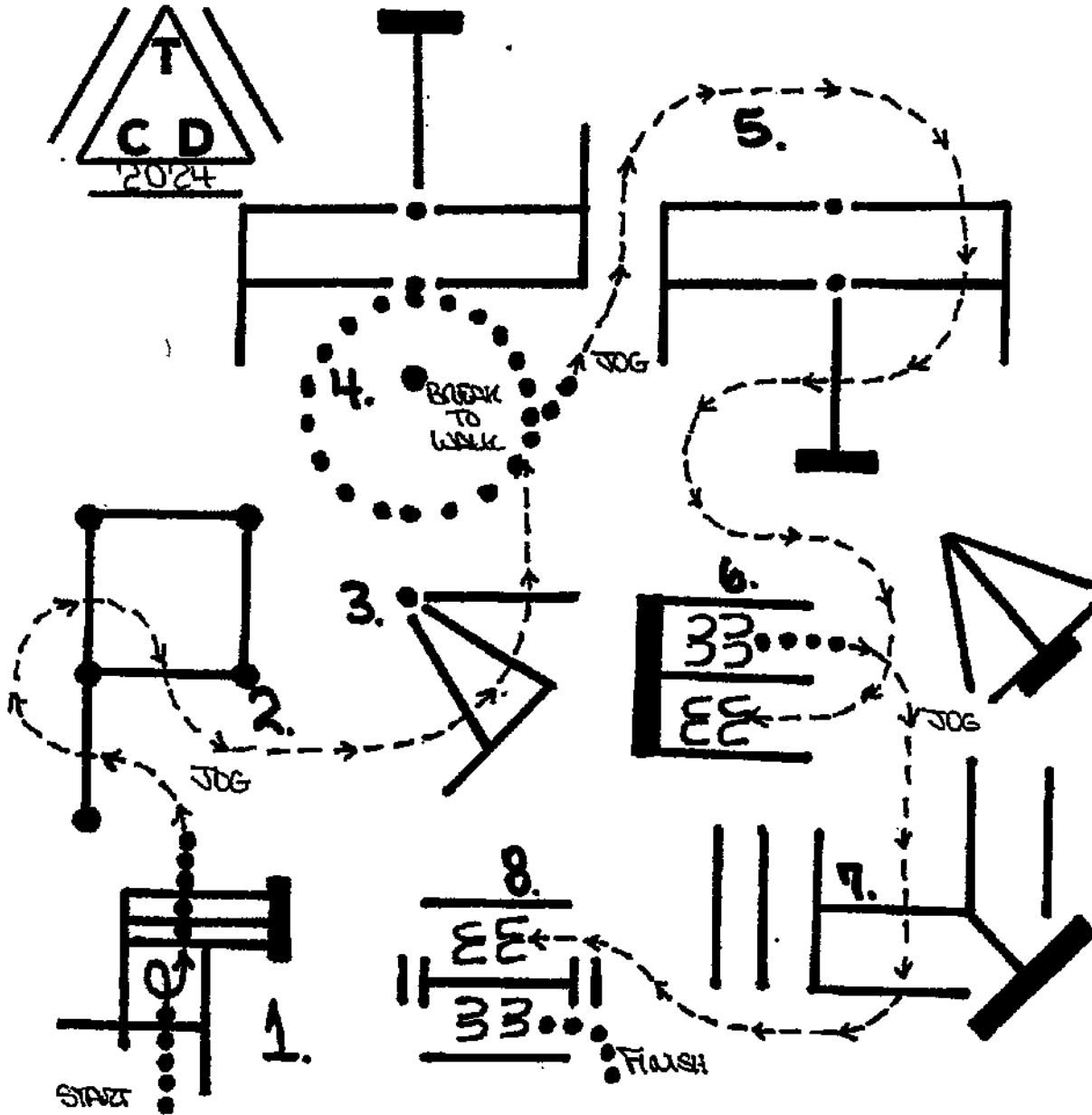

1. WALK INTO BOX 360 TURN LEFT, WALK OUT OVER POLES
2. JOG THRU SERPENTINE & OVER POLES
3. JOG OVER 3 POLES
4. BREAK TO WALK & AROUND CONE
5. JOG OVER 3 POLES & INTO CHUTE
6. BACK CHUTE TO CHUTE, WALK OUT
7. JOG OVER 2 POLES TO GATE
8. GATE-(LH) RIDE THRU CLOSE

CALIF. CHAMPIONSHIP

RANCH TRAIL

SUN. SEPT. 1, 2024

436-RANCH SR HORSE
437-RANCH SELECT AMA
438-RANCH AMATEUR

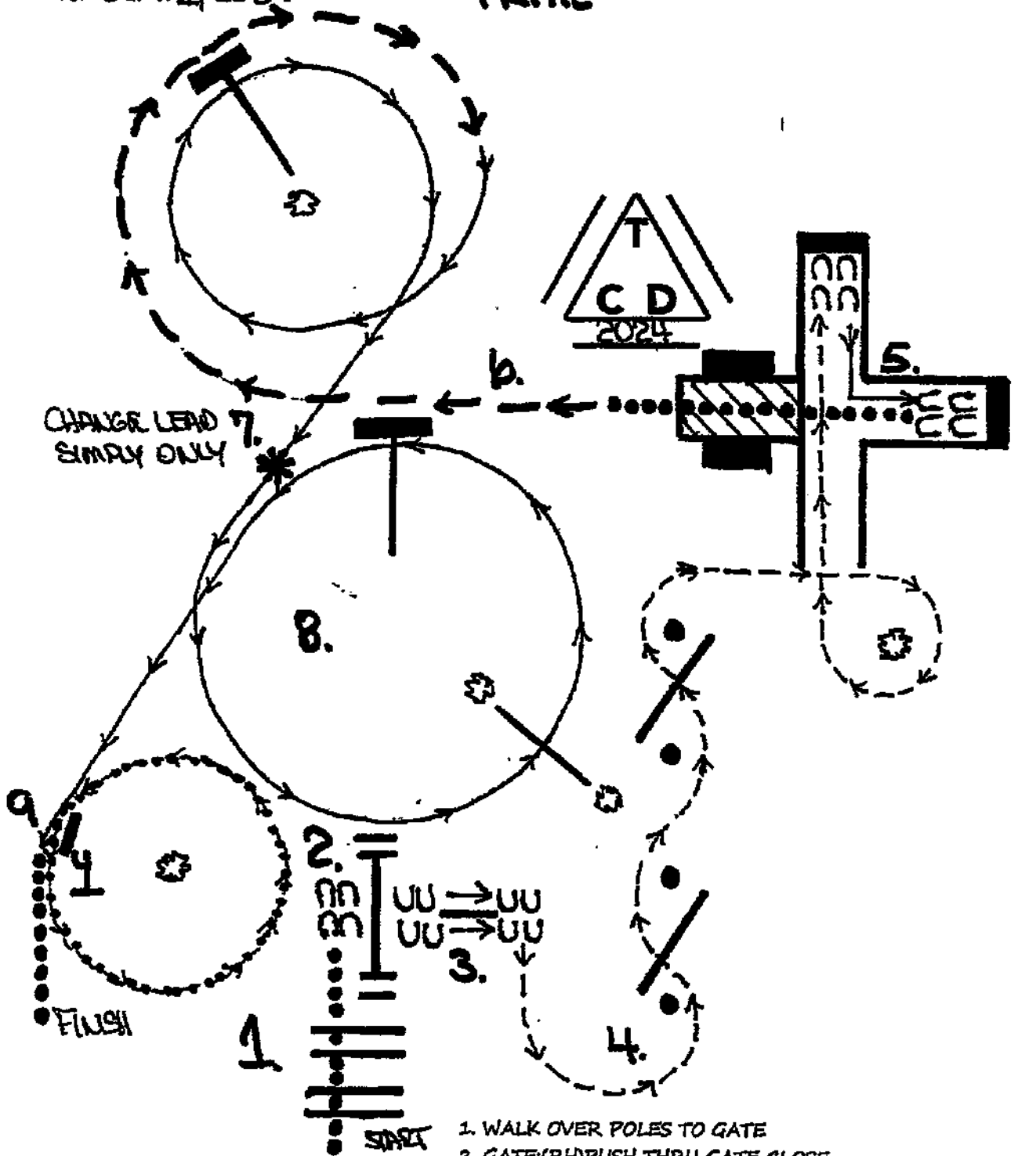

1. WALK OVER POLES TO GATE
2. GATE:(RH)PUSH THRU GATE CLOSE
3. SIDE PASS LEFT OVER POLE
4. TROT THRU SERPENTINE & OVER POLES & INTO CHUTE
5. BACK THRU POLES WALK OUT OF CHUTE OVER BRIDGE
6. EXTENDED TROT, LOPE OVER POLE (RL)
7. CHANGE LEADS (SIMPLE ONLY)
8. LOPE (LL) OVER POLES TO DRAG
9. PICK UP COAT, WALK/TROT AROUND MARKER REPLACE COAT WALK AWAY

CALIF. CHAMPIONSHIP

SUN. SEPT. 1, 2024

RANCH TRAIL

- 439-RANCH YTH
- 440-RANCH JR HORSE
- 441-RANCH OPEN L-1
- 442-RANCH AMATEUR
- 443-RANCH YTH L-1

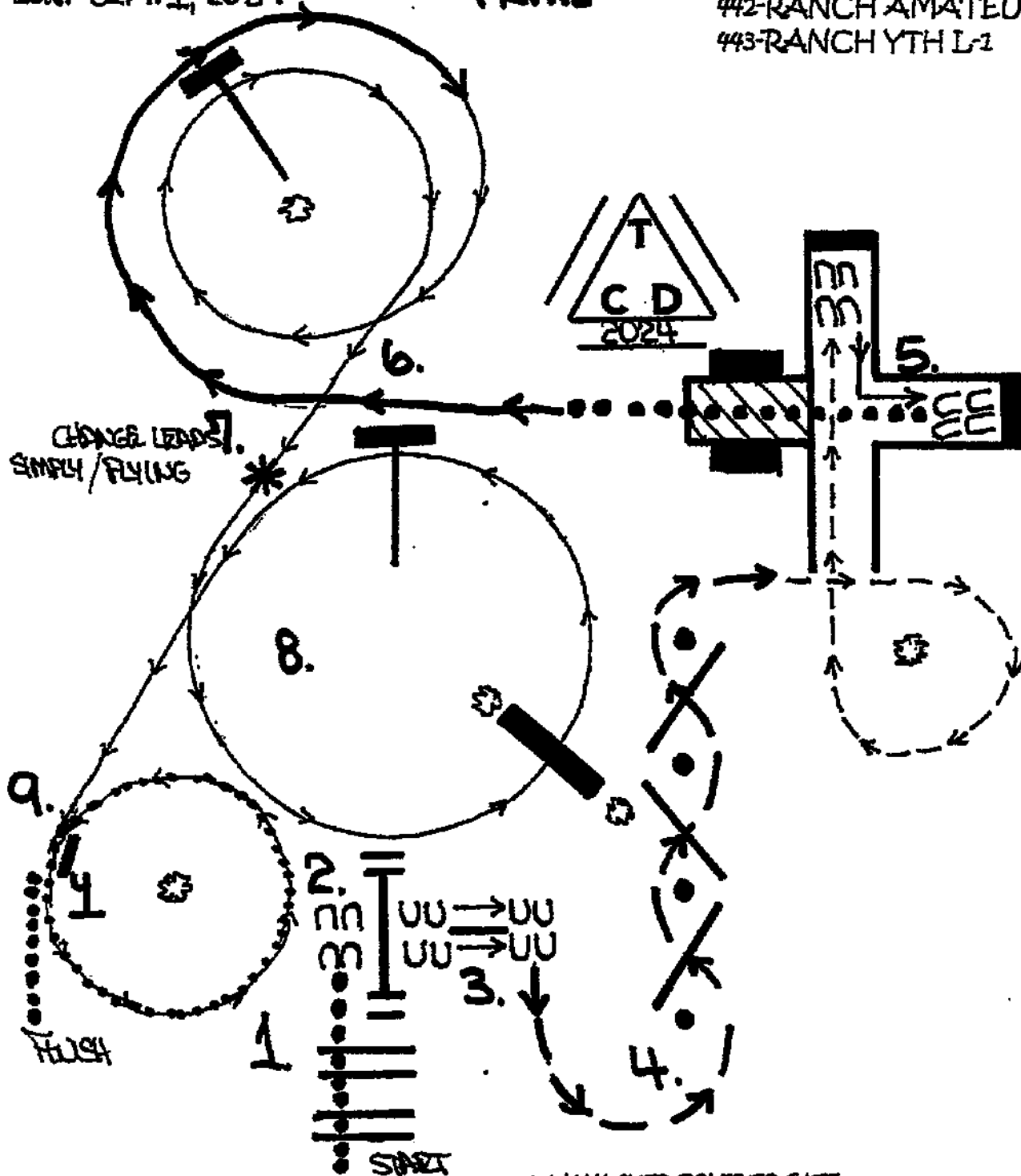

1. WALK OVER POLES TO GATE
2. GATE (RH) PUSH THRU GATE CLOSE
3. SIDE PASS LEFT OVER POLE
4. EXTENDED TROT THRU SERPENTINE & OVER POLES & INTO CHUTE
5. BACK THRU POLES WALK OUT OF CHUTE OVER BRIDGE
6. EXTENDED LOPE (RL) DOWN TO REGULAR LOPE & OVER POLE
7. CHANGE LEADS (SIMPLE/FLYING)
8. LOPE (LL) OVER JUMP & POLE TO DRAG
9. WORK DRAG, WALK AWAY

California Championship

Reining (L1 Youth, L1 Amateur, Junior, Green as Grass)

Show Date: Thursday 8-29-24

REINING PATTERN 6

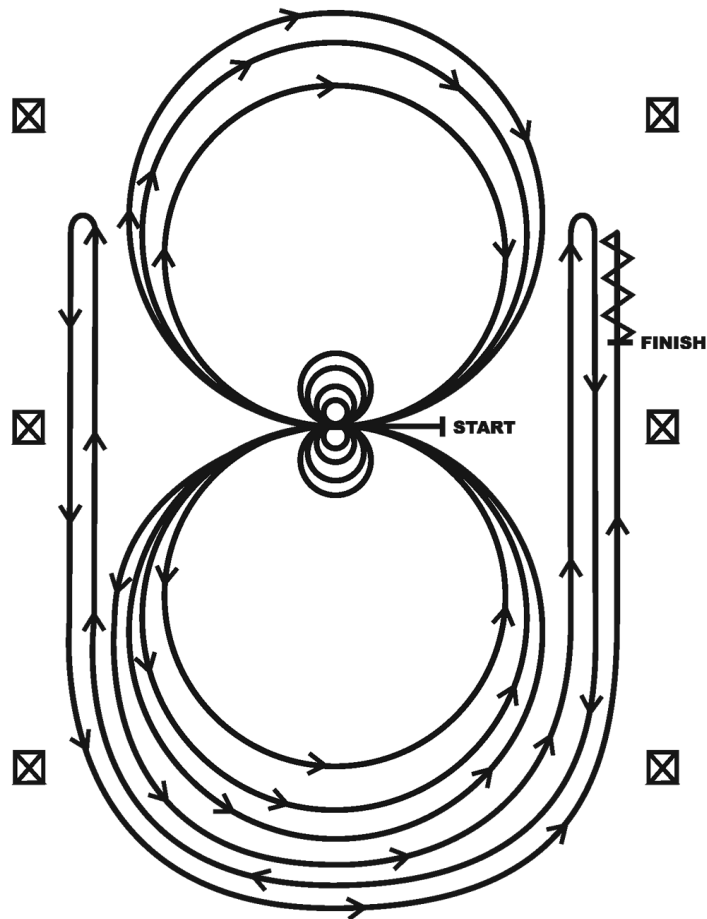

Horses may walk or jog to the center of arena. Horses must walk or stop prior to starting pattern. Beginning at the center of the arena facing the left wall or fence.

1. Complete four spins to the right. Hesitate.
2. Complete four spins to the left. Hesitate.
3. Beginning on the left lead, complete three circles to the left: the first two circles large and fast; the third circle small and slow. Change leads at the center of the arena.
4. Complete three circles to the right: the first two circles large and fast; the third circle small and slow. Change leads at the center of the arena.
5. Begin a large circle to the left but do not close this circle. Run up the right side of the arena past the center marker and do a right rollback at least twenty feet (six meters) from the wall or fence—no hesitation.
6. Continue back around previous circle but do not close this circle. Run up the left side of the arena past the center marker and do a left rollback at least twenty feet (six meters) from the wall or fence—no hesitation.
7. Continue back around previous circle but do not close this circle. Run up the right side of the arena past the center marker and do a sliding stop at least twenty feet (six meters) from the wall or fence. Back up at least ten feet (three meters). Hesitate to demonstrate the completion of the pattern.

[R/AQHAP-6]

Pattern Provided by:

The Judges

California Championship

Reining (Youth, Amateur, Senior)

Show Date: Thursday 8-29-24

REINING PATTERN 11

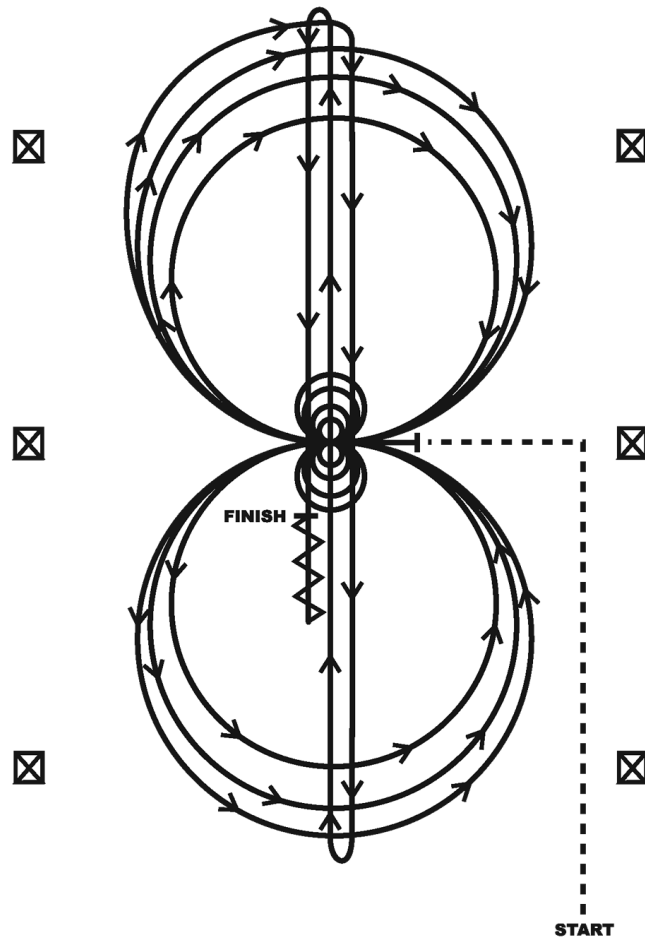

Horses must jog to the center of the arena. Horses must walk or stop prior to starting the pattern. Beginning at the center of the arena facing the left wall or fence.

1. Complete four spins to the left. Hesitate.
2. Complete four spins to the right. Hesitate.
3. Beginning on the right lead complete three circles to the right; the first circle small and slow; the next two circles large and fast. Change leads at the center of the arena.
4. Complete three circles to the left; the first circle small and slow; the next two circles large and fast. Change leads at the center of the arena.
5. Begin a large circle to the right, but do not close this circle. Run down the center of the arena past the end marker and do a right rollback—no hesitation.
6. Run up the middle to the opposite end of the arena past the end marker and do a left rollback—no hesitation.
7. Run past the center marker and do a sliding stop. Back up to the center of the arena or at least ten feet (three meters). Hesitate to demonstrate completion of the pattern.

[R/AQHAP-11]

Pattern Provided by:

The Judges

California Championship

All Ranch Riding except W/T

Show Date: Thursday 8-29-24

www.HorseShowPatterns.com

www.HorseShowPatterns.com

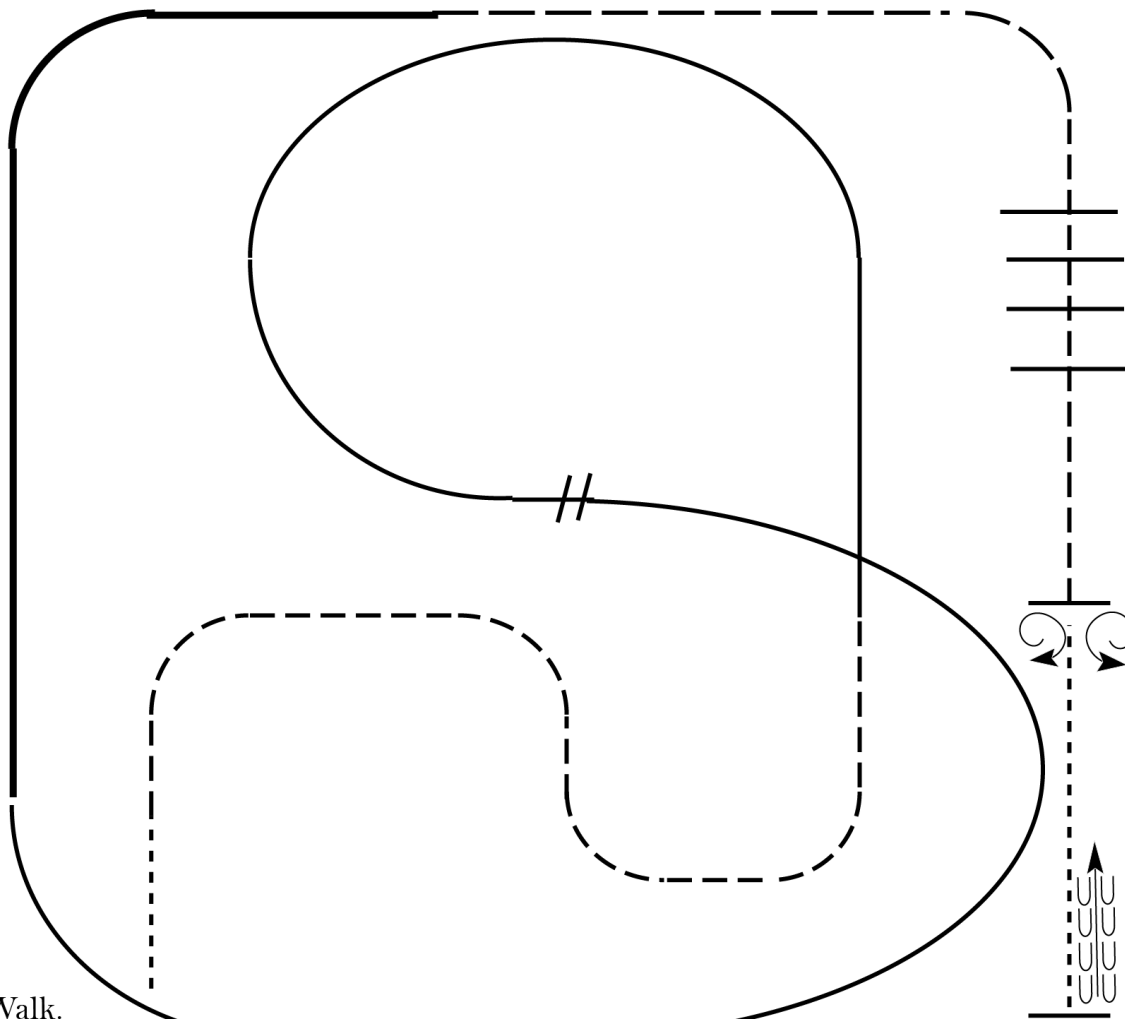

1. Walk.
2. Trot serpentine
3. Lope left lead around end of arena and then diagonally across arena.
4. Change leads (simple or flying) and
5. Lope on the right lead around end of the arena.
6. Extend lope on the straight away around corner to center of arena.
7. Extend trot around corner of arena
8. Collect to a trot
9. Trot over poles
10. Stop do a 360 turn each direction (either direction 1st)
11. Walk, stop and back.

Walk	-----
Jog	- - - - -
Extended Jog	-----
Lope	
Lead Change	//
Back	←
Marker	(B)

[RR/4]

Pattern Provided by:

The Judges

California Championship

Ranch Riding W/T

Show Date: Thursday 8-29-24

W W W . H O R S E S H O W P A T T E R N S . C O M

W W W . H O R S E S H O W P A T T E R N S . C O M

1. Walk
2. Trot serp

7. Extend trot ACROSS DIAGONAL AND CORNERS
8. Collect to a trot
9. Trot over poles
10. Stop do a 360 turn each direction (either direction 1st)
11. Walk, stop and back.

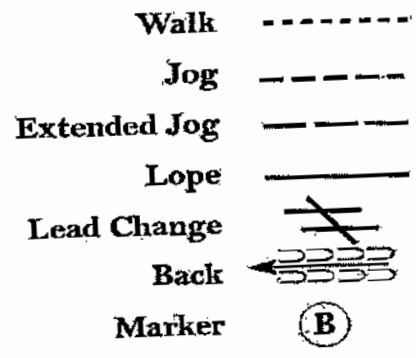

[RR/4]

Pattern Provided by:
The Judges

California Championship

Hunt Seat Equitation (L1 Youth, L1 Amateur)

Show Date: Friday 8-30-24

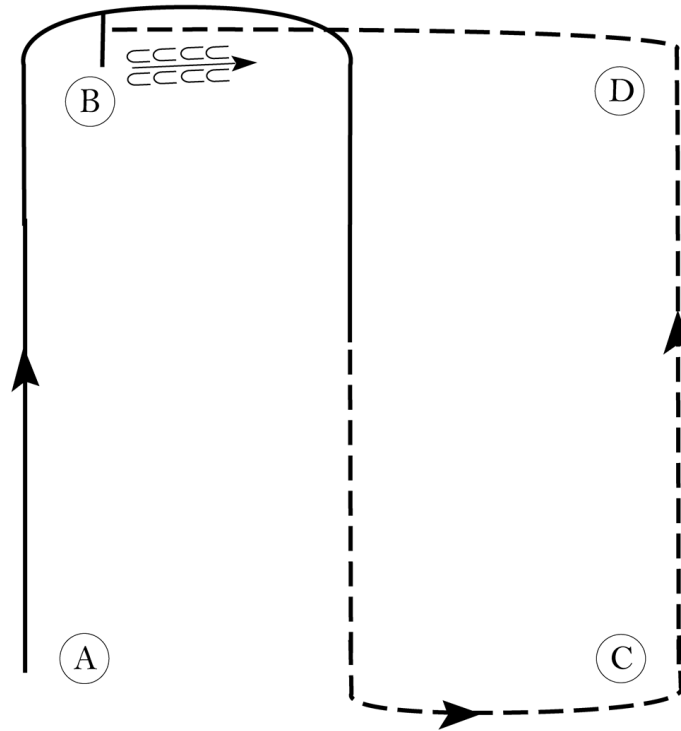

Be ready at A.

1. Canter on the right lead to and around B.
2. Halfway between B and C, break to the trot.
3. Posting trot on the right diagonal to C.
5. At C, change diagonals and continue to trot to D.
6. At D, sitting trot to B.
7. At B, stop and back one horse length.

Walk	-----
Trot	- - - - -
Extended Trot	— — — — —
Canter	— — — — —
Leg Yield	
Lead Change	— / —
Back	← ← ← ← ←
Marker	Ⓚ
Sidepass	← — — — — ←
Hand Gallop	— — — — —

[HSE/1-25]

Pattern Provided by:

The Judges

California Championship

Hunt Seat Equitation (Youth, Amateur, Select)

Show Date: Friday 8-30-24

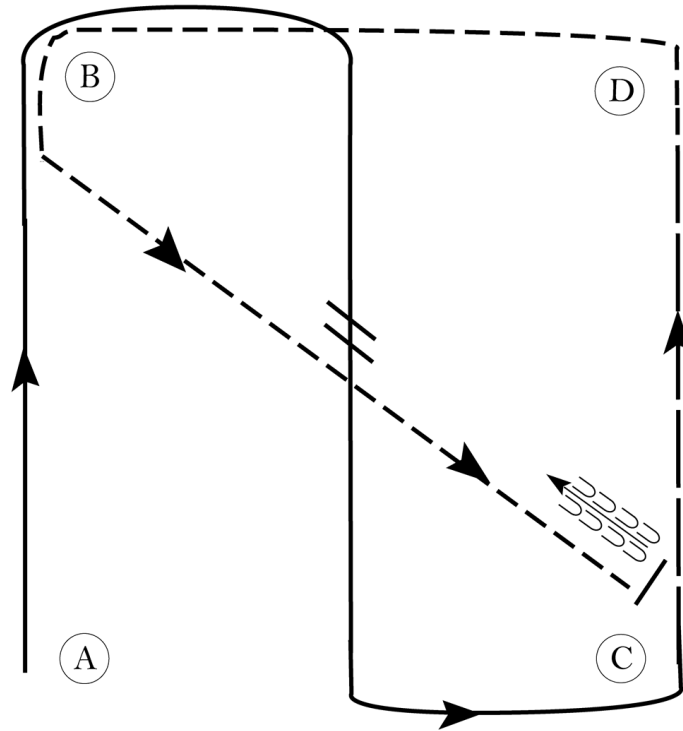

Be ready at A.

1. Canter on the right lead to and around B.
2. Halfway between B and C, change leads.
3. Canter on left lead to and around C.
4. Hand gallop from C to D.
5. At D, perform a posting trot on the right diagonal.
6. At B, two point at the trot until halfway to C.
7. Sitting trot to C.
8. Stop and back one horse length at C.

Walk
Trot	-----
Extended Trot	-----
Canter	—————
Leg Yield	
Lead Change	///
Back	←←←
Marker	ⓑ
Sidepass	←---←
Hand Gallop	-----

[HSE/3-25]

Pattern Provided by:

The Judges

California Championship

Hunt Seat Equitation (All W/T)

Show Date: Friday 8-30-24

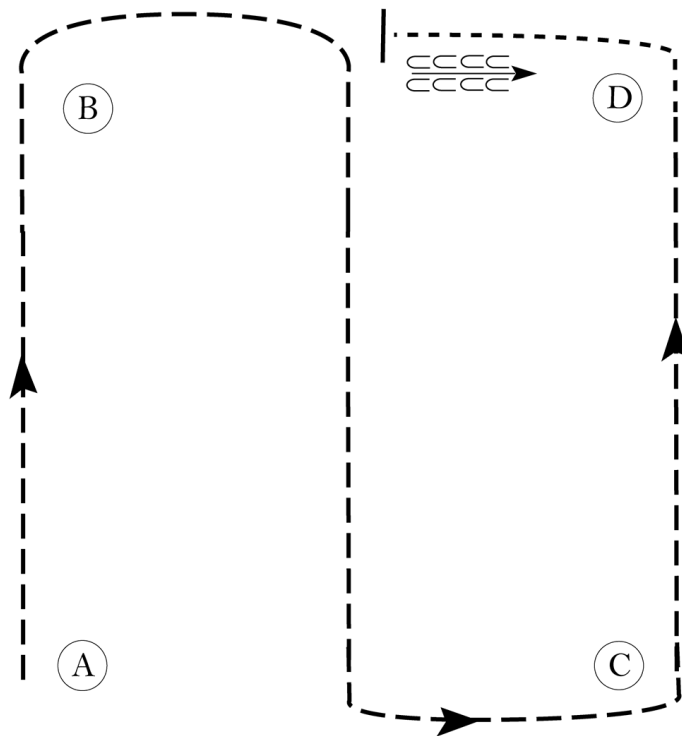

Be ready at A.

1. Posting trot to and around B on the left diagonal.
2. Halfway between B and C, change diagonals.
3. Posting trot on the right diagonal to and around C.
4. Continue to trot to D.
5. At D, walk.
6. Walk until halfway to B, stop and back one horse length.

Walk	-----
Trot	- - - - -
Extended Trot	— — — — —
Canter	— — — — —
Leg Yield	
Lead Change	— / —
Back	← ← ← ← ←
Marker	Ⓚ
Sidepass	← — — — — ←
Hand Gallop	— — — — —

[HSE/WT-25]

Pattern Provided by:

The Judges

w w w . H o r s e S h o w P a t t e r n s . c o m

w w w . H o r s e S h o w P a t t e r n s . c o m

California Championship

Horsemanship (L1 Youth, L1 Amateur)

Show Date: Friday 8-30-24

w w w . H o r s e S h o w P a t t e r n s . c o m

w w w . H o r s e S h o w P a t t e r n s . c o m

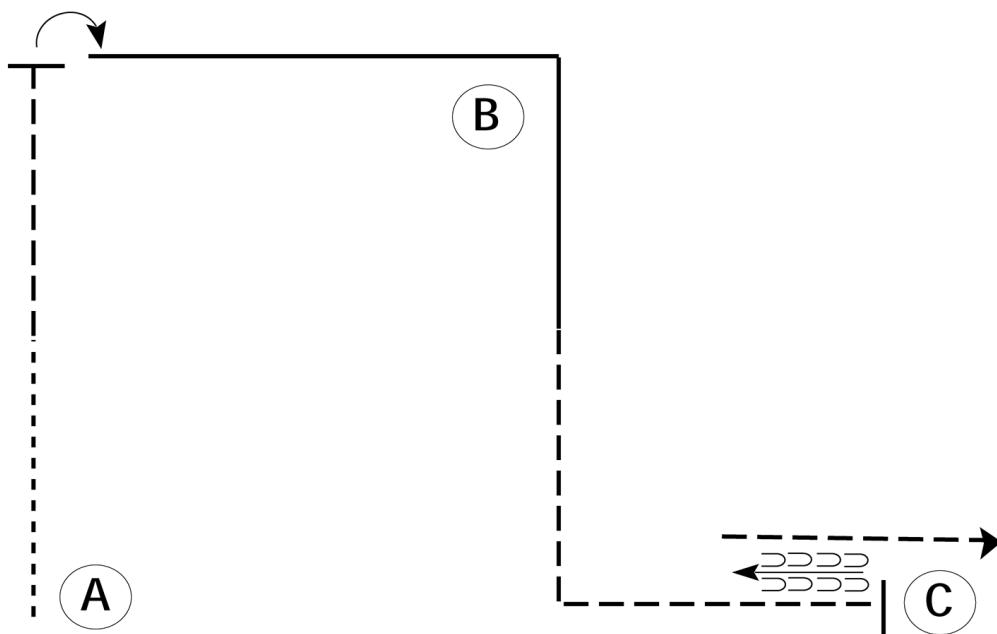

Be ready at A.

1. Walk from A to center of pattern.
2. Jog until just past B and stop.
3. Turn 1/4 turn to the right.
4. Lope on the right lead to and around B.
5. Break to the jog in the center of the pattern.
6. Jog until even with A and C. Jog a square corner to C.
7. Stop at C and back approximately one horse length.
8. Jog off past C.

Pattern is over once you pass C at the jog.

Follow the directions of your ring steward.

Walk	-----
Jog	- - - - -
Extended Jog	-----
Lope	—————
Lead Change	
Back	
Marker	(B)

[WH/1-81]

Pattern Provided by:
The Judges

California Championship

Horsemanship (Youth, Amateur, Select)

Show Date: Friday 8-30-24

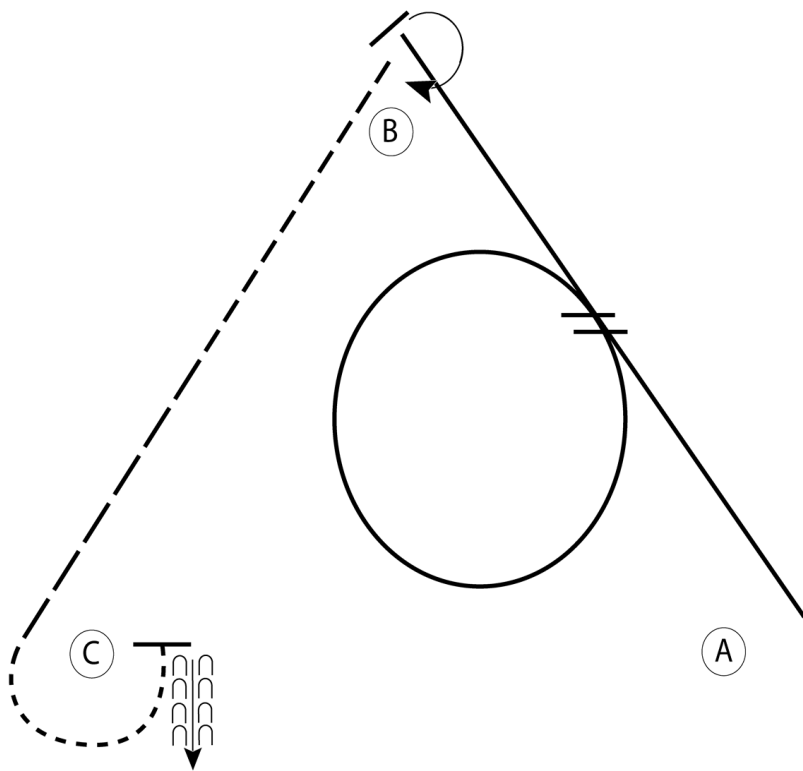

Be ready at A.

1. Lope on the left lead towards B.
 2. Halfway between A and B lope a circle to the left on the left lead.
 3. Half way between A and B perform a simple lead change.
 4. Lope past B. Stop and perform a 225 degree turn to the right.
 5. Jog towards C.
 6. Halfway between B and C extend the jog.
 7. At C walk, walk around C.
 8. At C stop and back approximately one horse length.
- Follow the instructions of your ring steward.

Walk - - - - -

Jog - - - - -

Extended Jog - - - - -

Lope _____

Leg Yield |||||

Lead Change / \

Back ← |||||

Marker (B)

Sidepass ← - - - - - →

[WH/3-3]

Pattern Provided by:

The Judges

California Championship

Horsemanship (All W/T)

Show Date: Friday 8-30-24

w w w . H o r s e S h o w P a t t e r n s . c o m

w w w . H o r s e S h o w P a t t e r n s . c o m

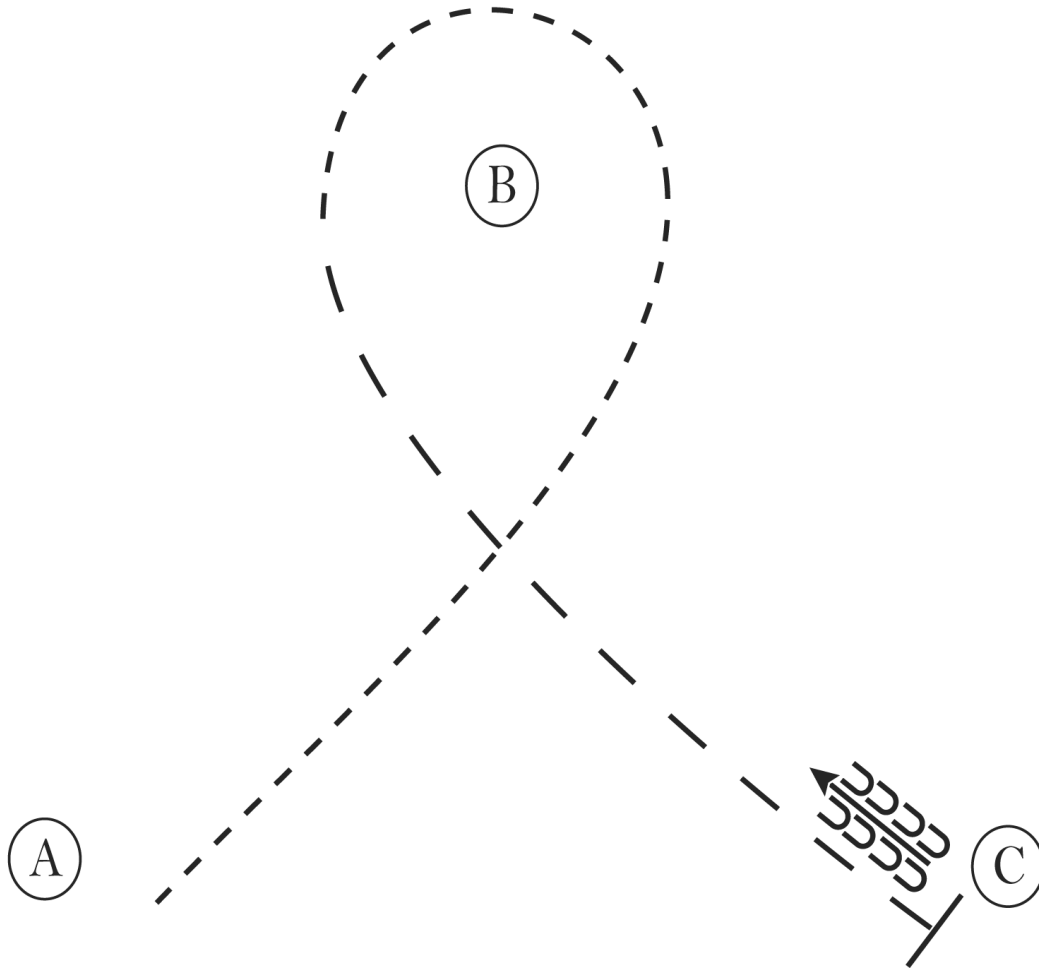

1. Jog A to B
2. Jog around B
3. Extend the jog at B to C.
4. At C stop and back 4 steps

Walk
Jog	-----
Extended Jog	-----
Lope	—————
Leg Yield	
Lead Change	↘
Back	← u u u u u u
Marker	(B)
Sidepass	←-----→

[WH/WT-9]

Pattern Provided by:

The Judges

Level 1 Youth & Amateur Showmanship

Show Date: Saturday 8-31-24

w w w . H o r s e S h o w P a t t e r n s . c o m

w w w . H o r s e S h o w P a t t e r n s . c o m

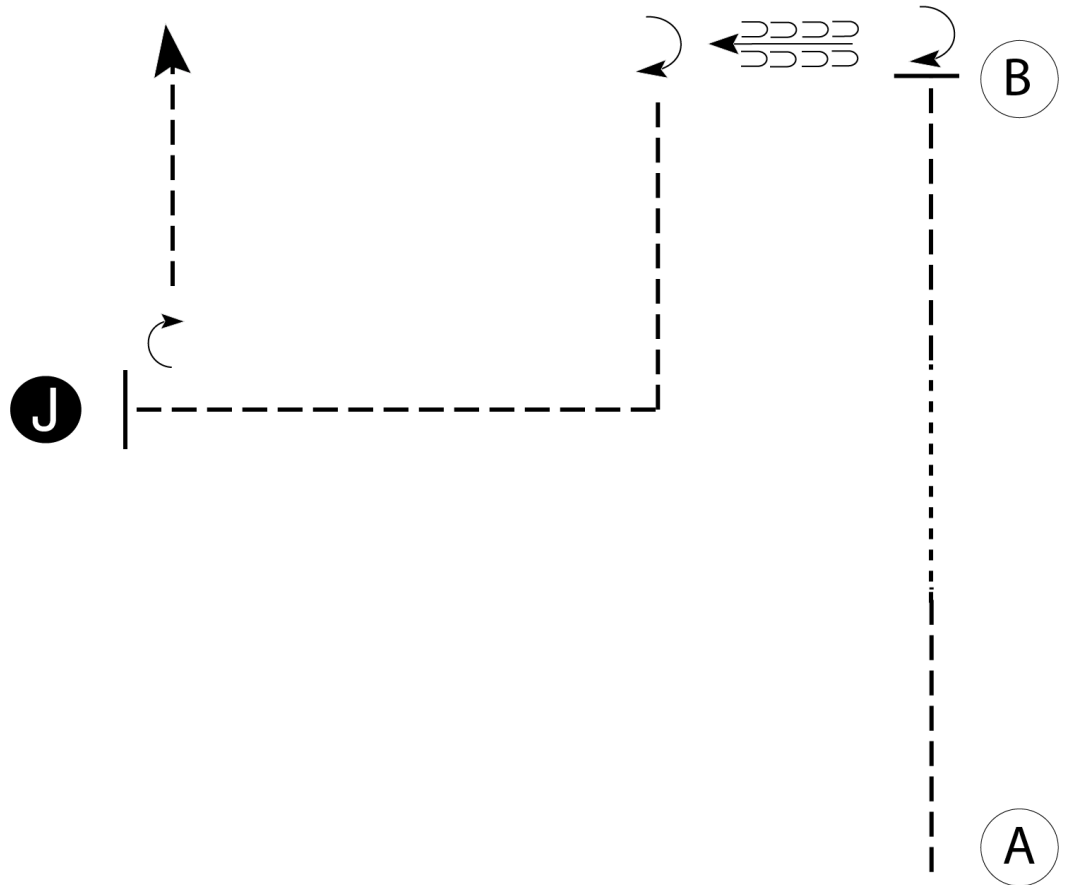

Be ready at A.

1. Trot 1/3 of the line, then walk 1/3 of the line then trot the final 1/3 of the line.
2. Stop with horse's hip even with B then perform a 1/4 turn.
3. Back 2 horse lengths then perform a 1/4 turn.
4. Trot to judge as shown.
5. Stop and set up at Judge.
6. Inspection.
7. When dismissed, perform a 1/4 turn and trot to exit.

Walk - - - - -
Trot - - - - -
Back ← - - - - -
Marker (B)
Judge (J)

[S/1-119]

Pattern Provided by:

JUDGES

Youth, Amateur & Select Showmanship

Show Date: Saturday 8-31-24

w w w . H o r s e S h o w P a t t e r n s . c o m

w w w . H o r s e S h o w P a t t e r n s . c o m

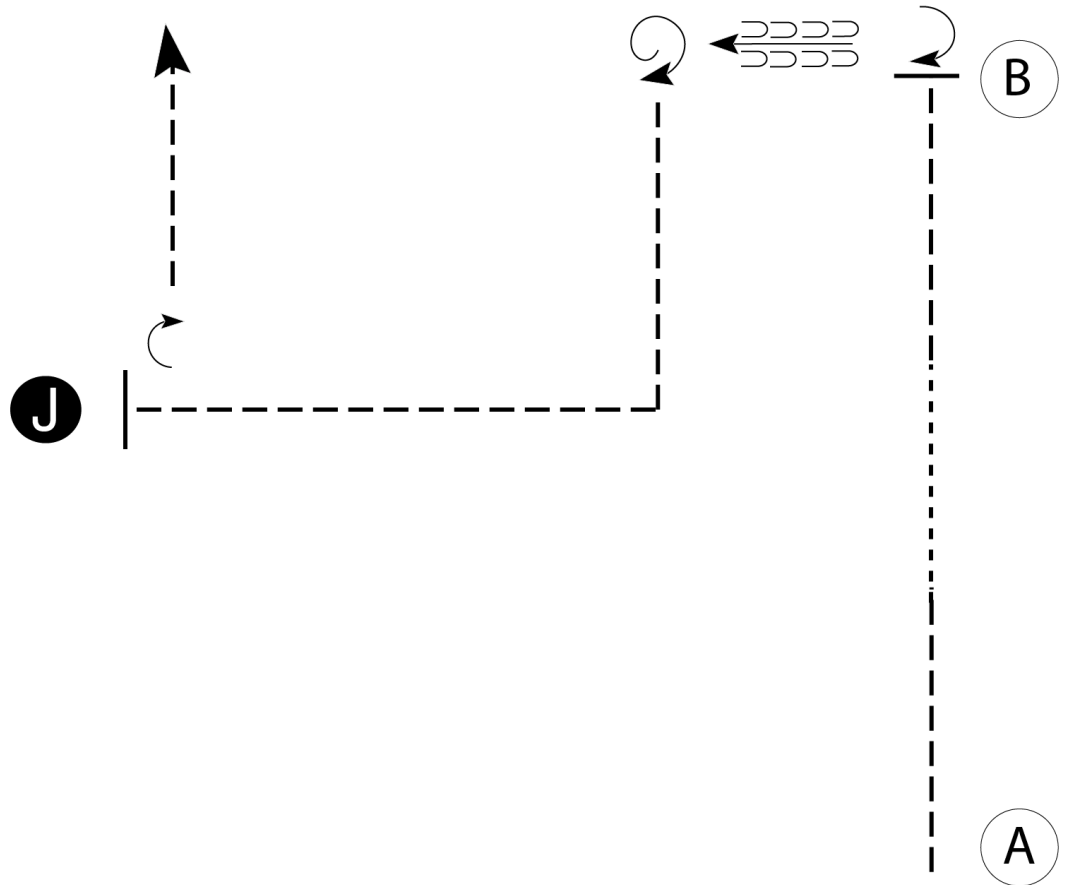

Be ready at A.

1. Trot 1/3 of the line, then walk 1/3 of the line then trot the final 1/3 of the line.
2. Stop with horse's hip even with B then perform a 1/4 turn.
3. Back 2 horse lengths then perform a 1 1/4 turn.
4. Trot to judge as shown.
5. Stop and set up at Judge.
6. Inspection.
7. When dismissed, perform a 1/4 turn and trot to exit.

- Walk -----
- Trot - . - . - .
- Back ← — — — — —
- Marker (B)
- Judge (J)

[S/2-119]

Pattern Provided by:

JUDGES

Walk/Jog Showmanship

Show Date: Saturday 8-31-24

w w w . H o r s e S h o w P a t t e r n s . c o m

w w w . H o r s e S h o w P a t t e r n s . c o m

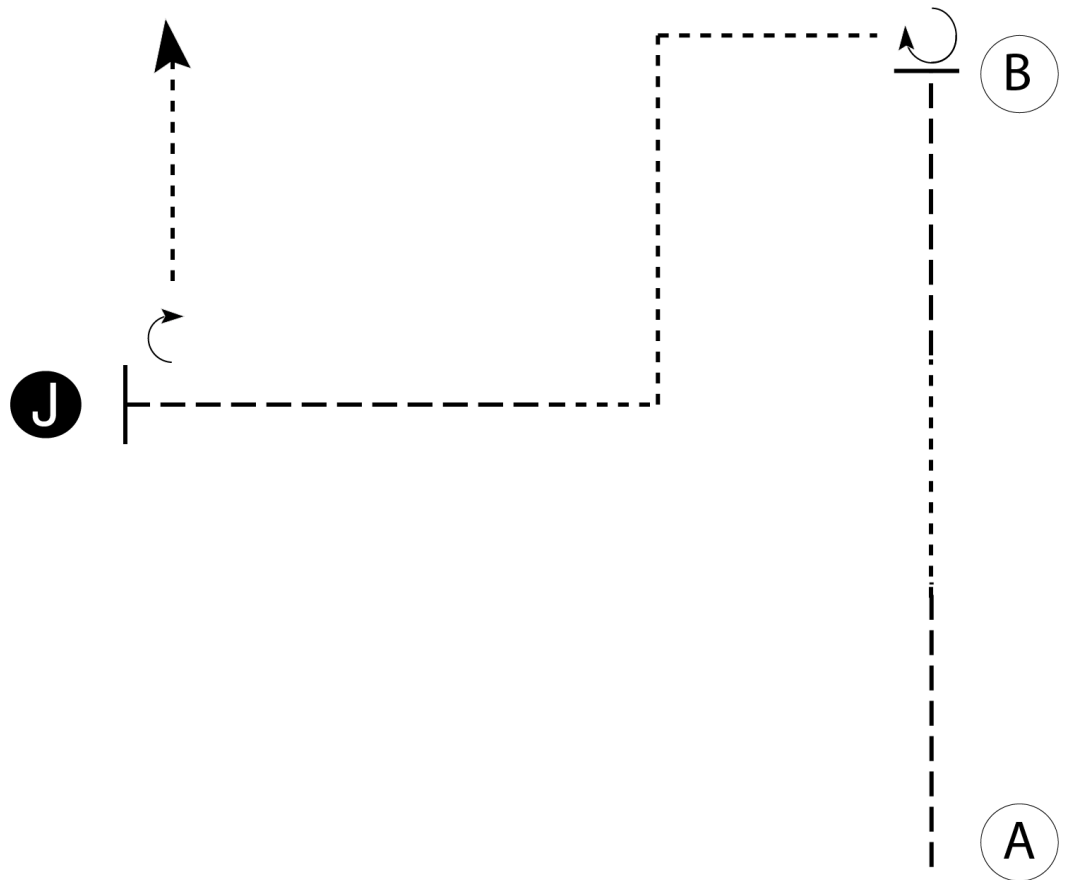

Be ready at A.

1. Trot 1/3 of the line, then walk 1/3 of the line then trot the final 1/3 of the line.
2. Stop with horse's hip even with B.
3. Perform a 3/4 turn.
4. Walk two square corners as shown then trot to judge.
5. Stop and set up at Judge.
6. Inspection.
7. When dismissed, perform a 1/4 turn and walk to exit.

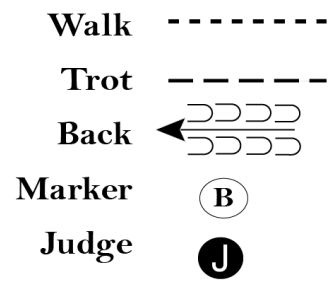

[S/WT-119]

Pattern Provided by:

JUDGES

California Championship

Hunt Seat Equitation (L1 Youth, L1 Amateur)

Show Date: Saturday 8-31-24

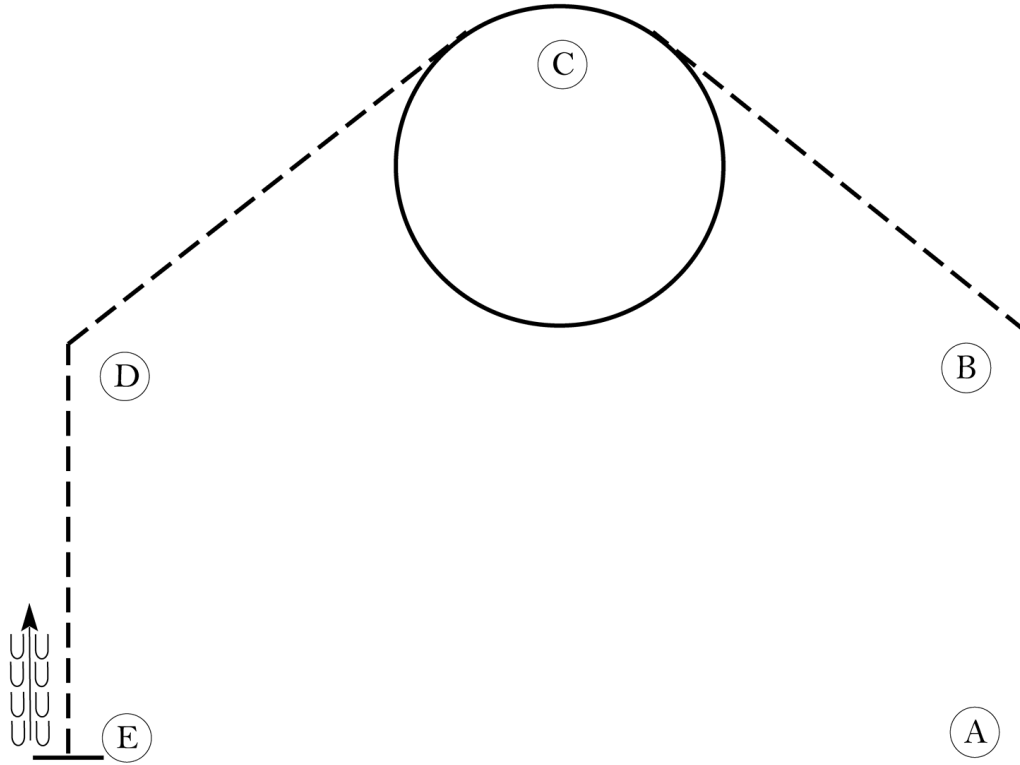

Be ready at A.

1. Walk approximately 2 horse lengths from A.
2. Trot on the right diagonal to C.
3. Canter a circle on the left lead around C.
4. Sitting trot to D.
5. Trot on the left diagonal to E.
6. Halt at E and back approximately one horse length.

When dismissed, follow the instructions of your ring steward.

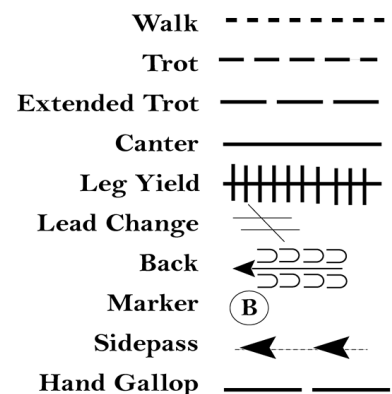

[HSE/1-37]

Pattern Provided by:

The Judges

California Championship

Hunt Seat Equitation (Youth, Amateur, Select)

Show Date: Saturday 8-31-24

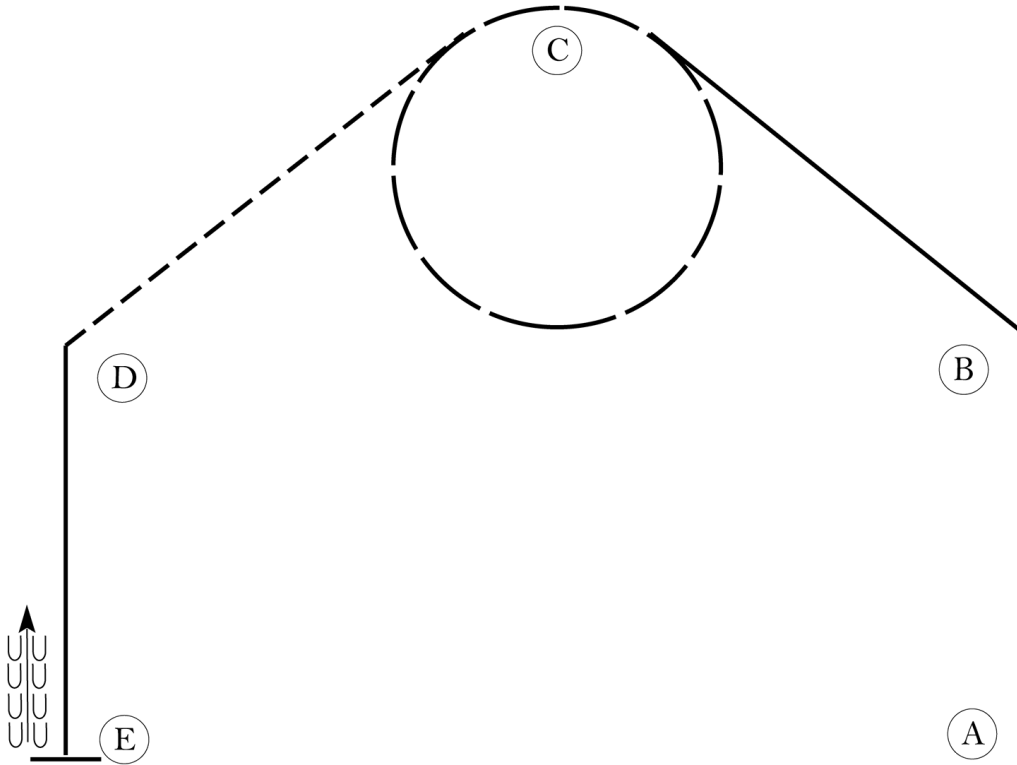

Be ready at A.

1. Walk approximately 2 horse lengths from A.
2. Trot on the right diagonal to B.
3. Canter on the left lead to C.
4. Hand gallop a circle around C.
5. Trot on the left diagonal to D.
6. Canter on the right lead to E.
7. Halt at E and back approximately one horse length.

When dismissed, follow the instructions of your ring steward.

Walk
Trot	-----
Extended Trot	-----
Canter	—————
Leg Yield	
Lead Change	↘↘↘
Back	←←←
Marker	(B)
Sidepass	←-----←
Hand Gallop	—————

[HSE/3-37]

Pattern Provided by:

The Judges

California Championship

Hunt Seat Equitation (All W/T)

Show Date: Saturday 8-31-24

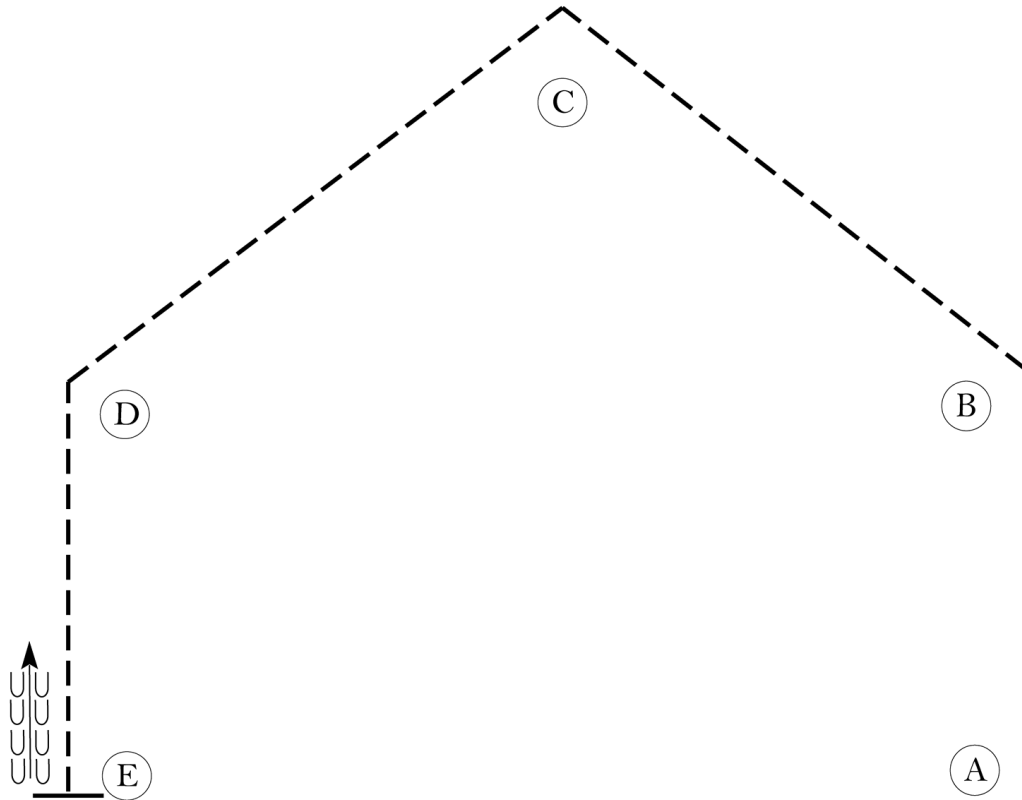

Be ready at A.

1. Walk to B.
2. Trot on the left diagonal to C.
3. Change diagonals and trot on the right diagonal to D.
4. Sitting trot to E.
5. Halt at E and back approximately one horse length.

When dismissed, follow the instructions of your ring steward.

Walk	-----
Trot	- - - - -
Extended Trot	— — — — —
Canter	—————
Leg Yield	
Lead Change	↘
Back	←←←←←
Marker	⊙
Sidepass	←←←←←
Hand Gallop	—————

[HSE/WT-37]

Pattern Provided by:

The Judges

California Championship

Western Riding (All L1)

Show Date: Saturday 8-31-24

w w w . H o r s e S h o w P a t t e r n s . c o m

w w w . H o r s e S h o w P a t t e r n s . c o m

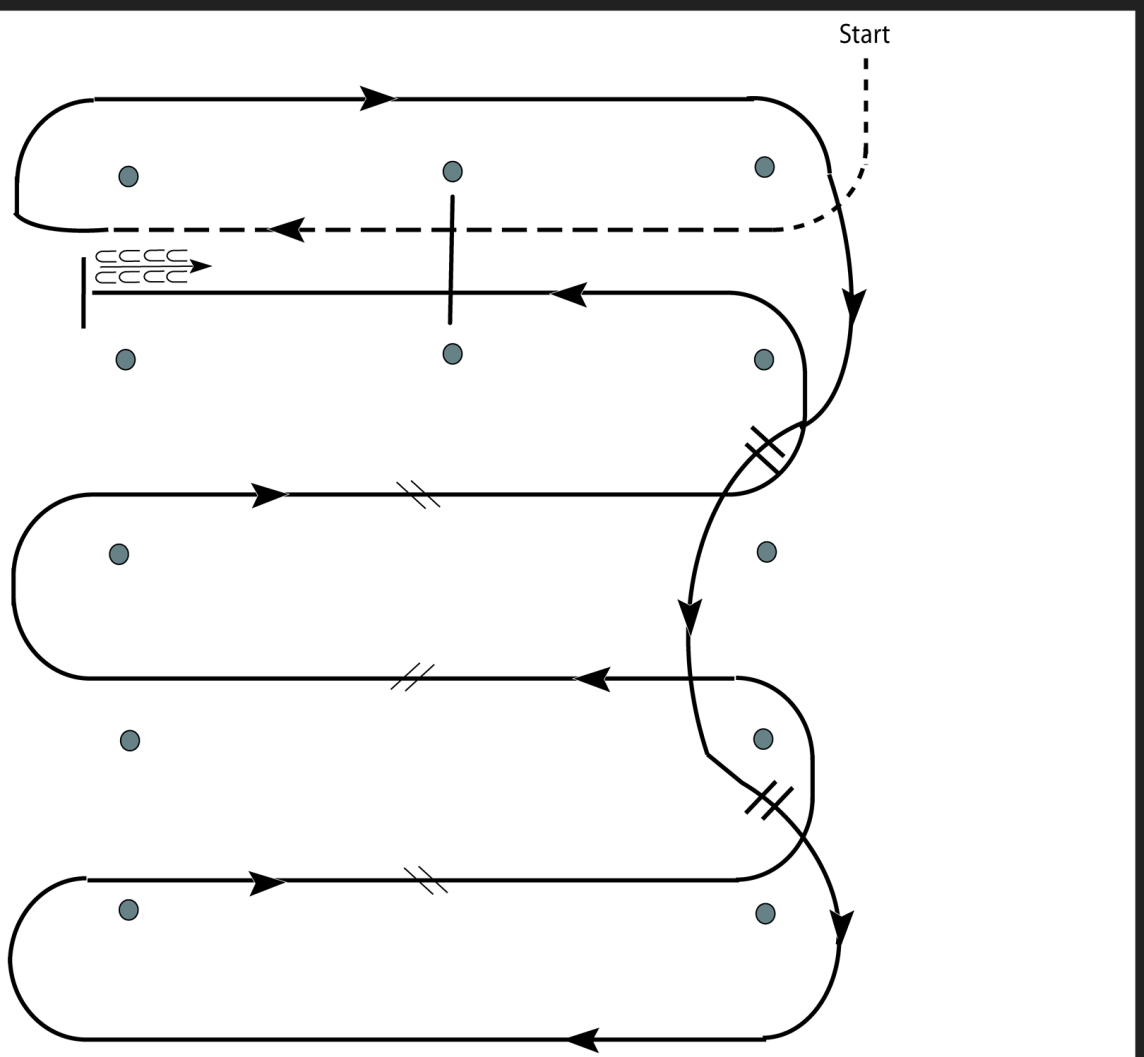

1. Walk, transition to jog, jog over log.
2. Transition to right lead and lope around end.
3. First line change.
4. Second line change. Lope around end of arena.
5. First crossing change.
6. Second crossing change.
7. Third crossing change.
8. Lope over log.
9. Lope, stop and back.

[WR/GP-4]

Pattern Provided by:
The Judges

California Championship

Western Riding (Youth, Amateur, Select, Junior, Senior)

Show Date: Saturday 8-31-24

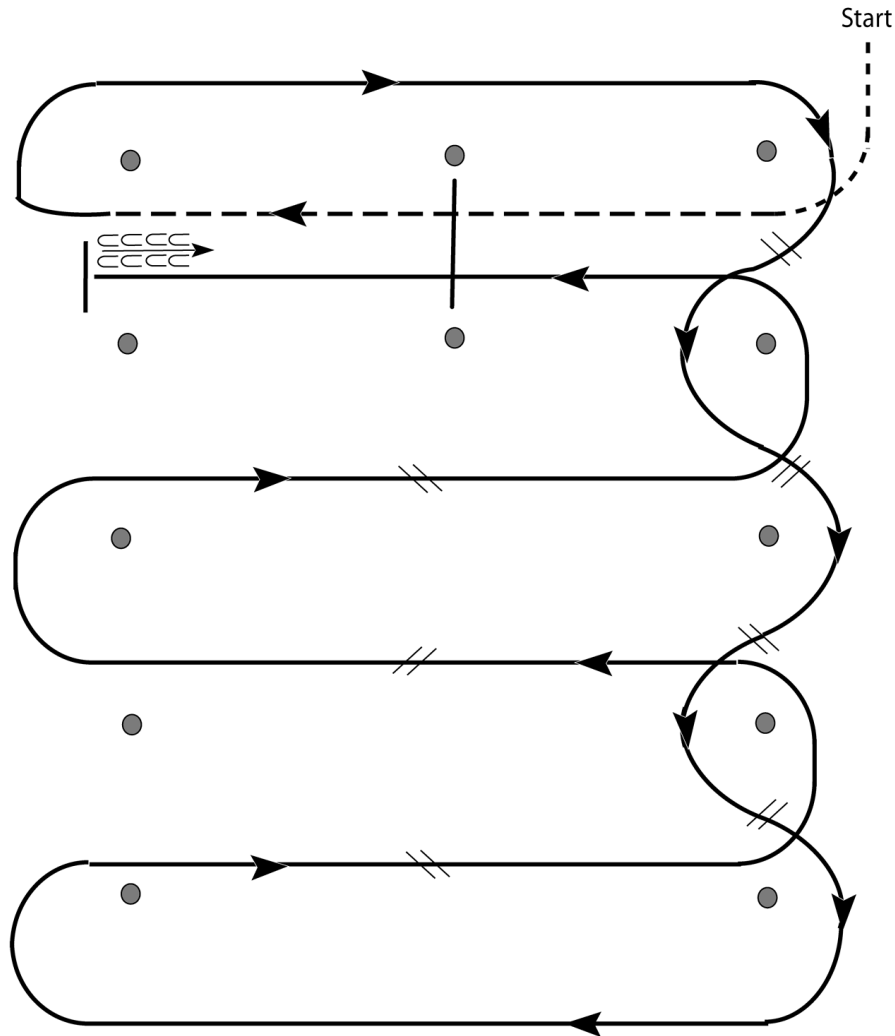

1. Walk, transition to jog, jog over log.
2. Transition to right.
3. First line change.
4. Second line change.
5. Third line change.
6. Fourth line change.
7. First crossing change.
8. Second crossing change.
9. Third crossing change.
10. Lope over log.
11. Lope, stop and back.

[WR/OP-4]

Pattern Provided by:

The Judges

California Championship

All Ranch Riding except W/T

Show Date: *Uæ ĩåæ Å ĒFĒG*

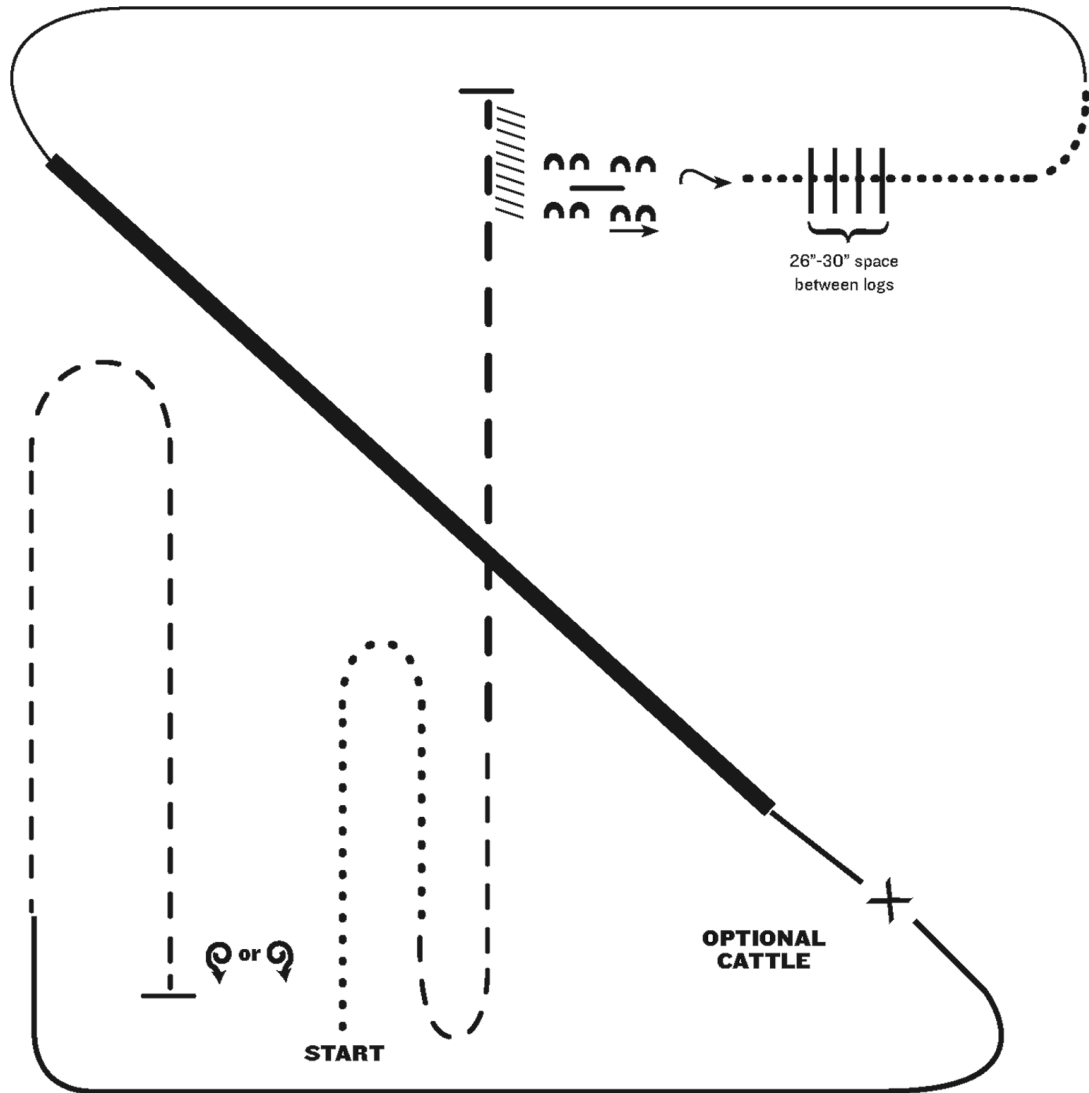

1. Walk
2. Trot
3. Extended trot
4. Stop and back
5. Side pass over log right
6. 1/4 turn right, walk over logs
7. Walk
8. Lope left lead
9. Extended lope (left lead)
10. Collect lope, change leads (simple or flying)
11. Lope right lead
12. Trot
13. Stop, one 360 degree turn either direction

Note: The drawn description of this pattern is only intended for the general depiction of the pattern. Exhibitors should utilize the arena space to best exhibit their horses.

[RR/AQHA-7]

Pattern Provided by:

The Judges

California Championship

Reining (L1 Youth, L1 Amateur, Junior, Green as Grass)

Show Date: Saturday 8-31-24

REINING PATTERN 5

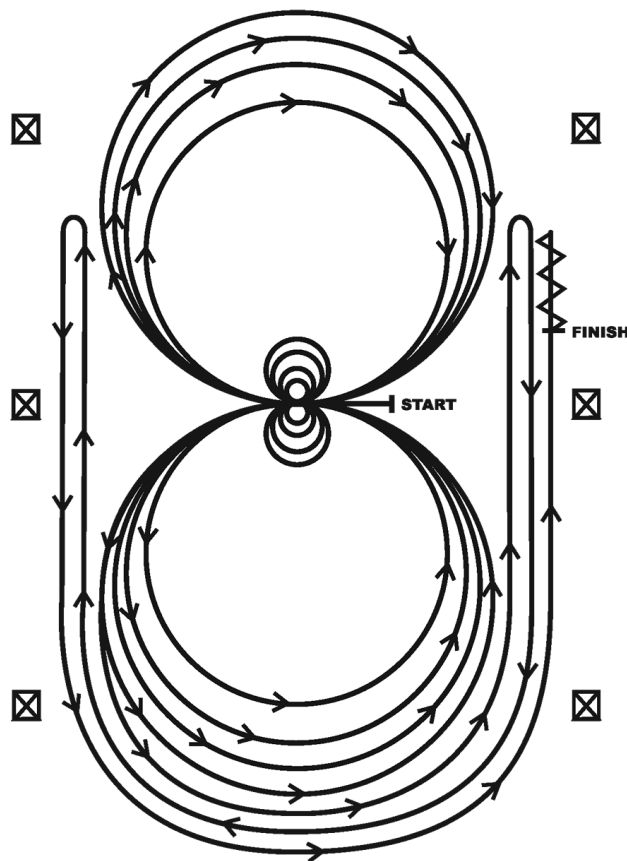

Horses may walk or jog to the center of arena. Horses must walk or stop prior to starting pattern. Beginning at the center of the arena facing the left wall or fence.

1. Beginning on the left lead, complete three circles to the left: the first two circles large and fast; the third circle small and slow. Stop at the center of the arena. Hesitate.
2. Complete four spins to the left. Hesitate.
3. Beginning on the right lead, complete three circles to the right: the first two circles large and fast; the third circle small and slow. Stop at the center of the arena. Hesitate.
4. Complete four spins to the right. Hesitate.
5. Beginning on the left lead, run a large fast circle to the left, change leads at the center of the arena, run a large fast circle to the right, and change leads at the center of the arena. (Figure 8)
6. Continue around previous circle to the left but do not close this circle. Run up the right side of the arena past the center marker and do a right rollback at least twenty feet (six meters) from the wall or fence—no hesitation.
7. Continue around previous circle but do not close this circle. Run up the left side of the arena past the center marker and do a left rollback at least twenty feet (six meters) from the wall or fence—no hesitation.
8. Continue back around previous circle but do not close this circle. Run up the right side of the arena past the center marker and do a sliding stop at least twenty feet (six meters) from the wall or fence. Back up at least ten feet (three meters). Hesitate to demonstrate completion of the pattern.

[R/AQHAP-5]

Pattern Provided by:

The Judges

California Championship

Reining (Youth, Amateur, Senior)

Show Date: Saturday 8-31-24

REINING PATTERN 9

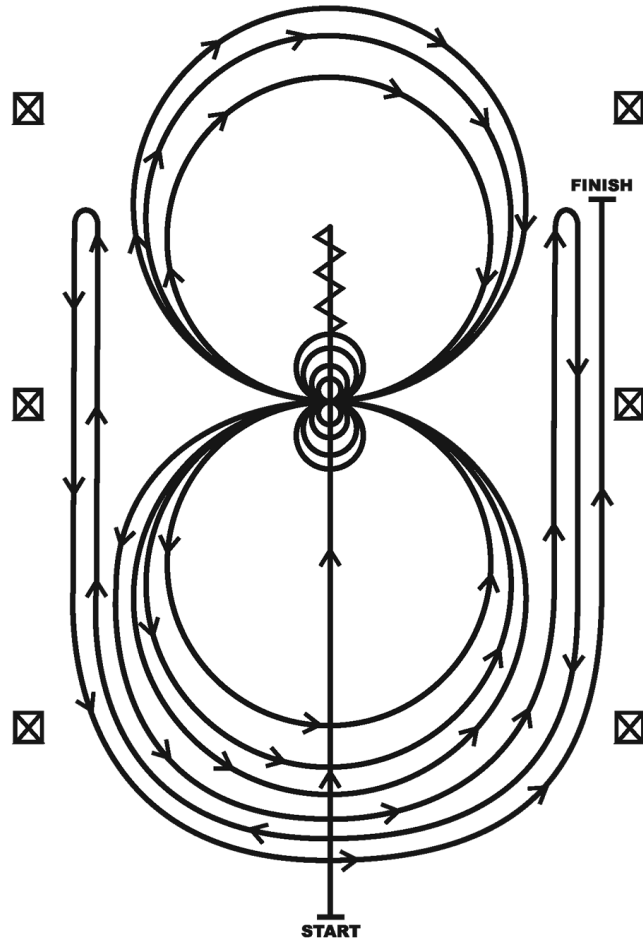

1. Run past the center marker and do a sliding stop. Back up to the center of the arena or at least ten feet (three meters). Hesitate.
2. Complete four spins to the right. Hesitate.
3. Complete four and one-quarter spins to the left so that horse is facing the left wall or fence. Hesitate.
4. Beginning on the left lead, complete three circles to the left: the first circle small and slow; the next two circles large and fast. Change leads at the center of the arena.
5. Complete three circles to the right: the first circle small and slow; the next two circles large and fast. Change leads at the center of the arena.
6. Begin a large circle to the left but do not close this circle. Run up the right side of the arena past the center marker and do a right rollback at least twenty feet (six meters) from the wall or fence—no hesitation.
7. Continue back around the previous circle but do not close this circle. Run up the left side of the arena past the center marker and do a left rollback at least twenty feet (six meters) from the wall or fence—no hesitation.
8. Continue back around previous circle but do not close this circle. Run up right side of the arena past the center marker and do a sliding stop at least twenty feet (six meters) from the wall or fence. Hesitate to demonstrate completion of the pattern.

[R/AQHAP-9]

Pattern Provided by:

The Judges

California Championship

Ranch Riding (All Ranch Riding)

Show Date: SATURDAY 8-31-24

WWW.HORSESHOWPATTERNS.COM

WWW.HORSESHOWPATTERNS.COM

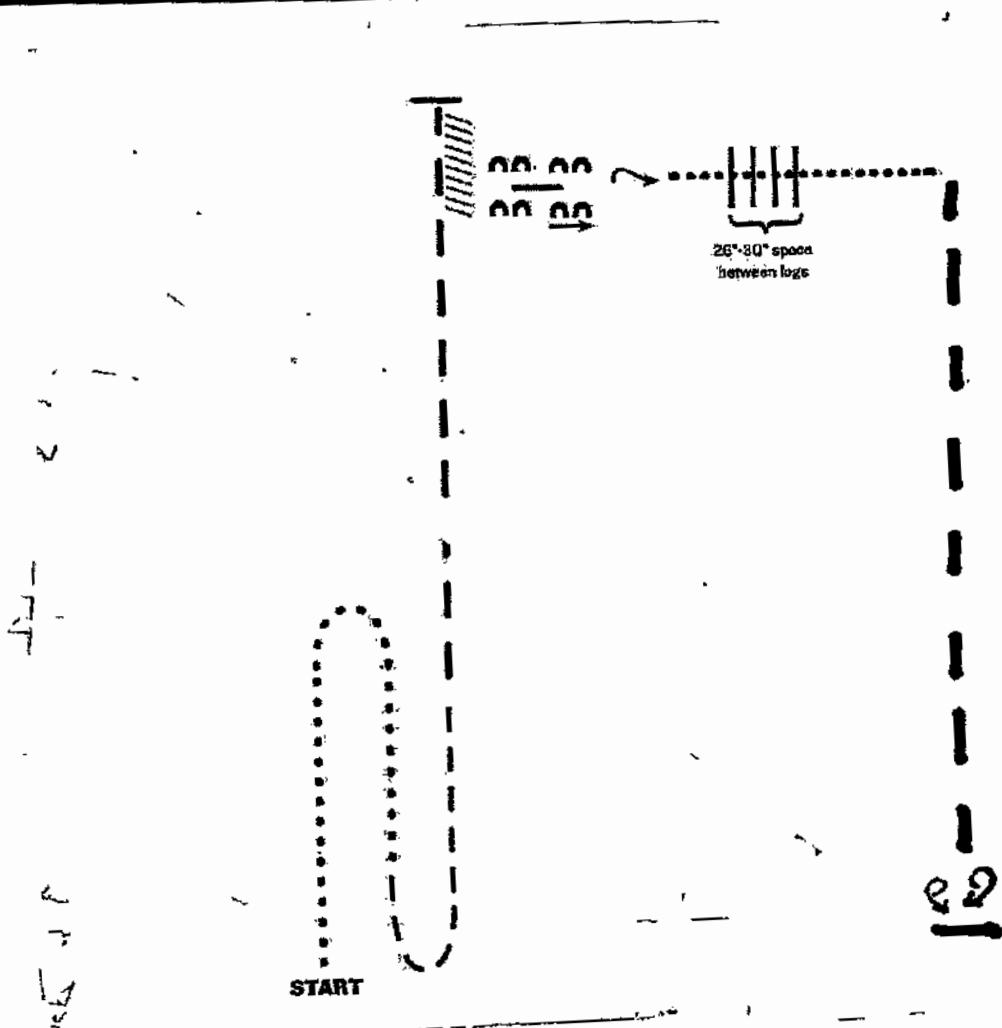

1. Walk
2. Trot
3. Extended trot
4. Stop and back
5. Side pass over log right
6. 1/4 turn right; walk over logs
7. Walk
8. EXTENDED TROT
9. STOP (360) EITHER WAY

Note: The drawn description of this pattern is only intended for the general depiction of the pattern. Exhibitors should utilize the arena space to best exhibit their horses.

[RR/AQHA-7]

Pattern Provided by:

The Judges

California Championship

Horsemanship (L1 Youth, L1 Amateur)

Show Date: Sunday 9-1-24

www.HorseShowPatterns.com

www.HorseShowPatterns.com

1. Jog A to B.
2. Stop at B and perform a 180 degree turn to the right on the hindquarters.
3. Jog a circle to the left.
4. At B lope a circle to the right on the right lead.
5. Stop at B and perform a 180 degree turn to the left.
6. Jog B to C.
7. Stop at C.

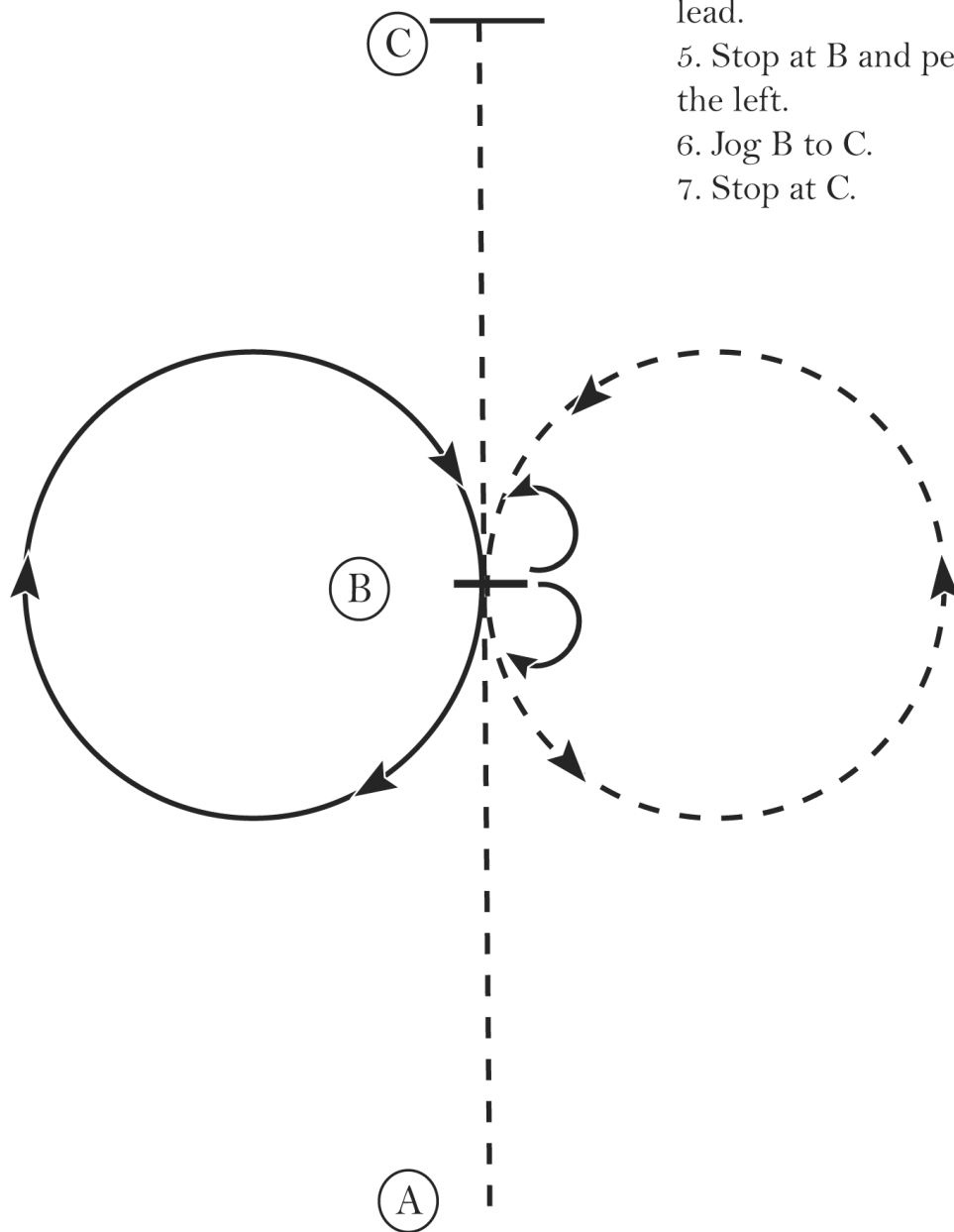

Walk
Jog	- - - - -
Extended Jog	- - - - -
Lope	—————
Leg Yield	
Lead Change	↘
Back	←←←←← ←←←←←
Marker	(B)
Sidepass	←- - - ->

[WH/1-10]

Pattern Provided by:

The Judges

California Championship

Horsemanship (Youth, Amateur, Select)

Show Date: Sunday 9-1-24

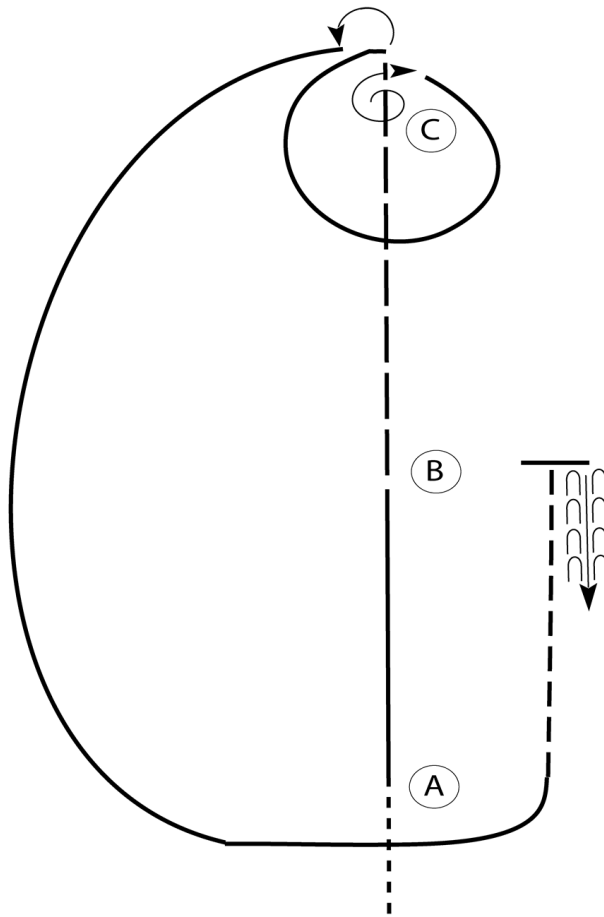

Be ready before A.

1. Walk to A.
2. At A, lope on the left lead to B.
3. At B, extend the jog to past C.
4. Stop and perform a 450 degree turn to the right.
5. Lope a circle around C on the right lead.
6. Stop at C and perform a 180 degree turn to the left.
7. Lope a large fast half circle to and around A .
8. At A, jog to B.
9. Stop at B and back 4 approximately one horse length.

Walk	-----
Jog	-----
Extended Jog	-----
Lope	-----
Lead Change	
Back	
Marker	(B)

[WH/3-8]

Pattern Provided by:
The Judges

www.HorseShowPatterns.com

www.HorseShowPatterns.com

California Championship

Horsemanship (All W/T)

Show Date: Sunday 9-1-24

w w w . H o r s e S h o w P a t t e r n s . c o m

w w w . H o r s e S h o w P a t t e r n s . c o m

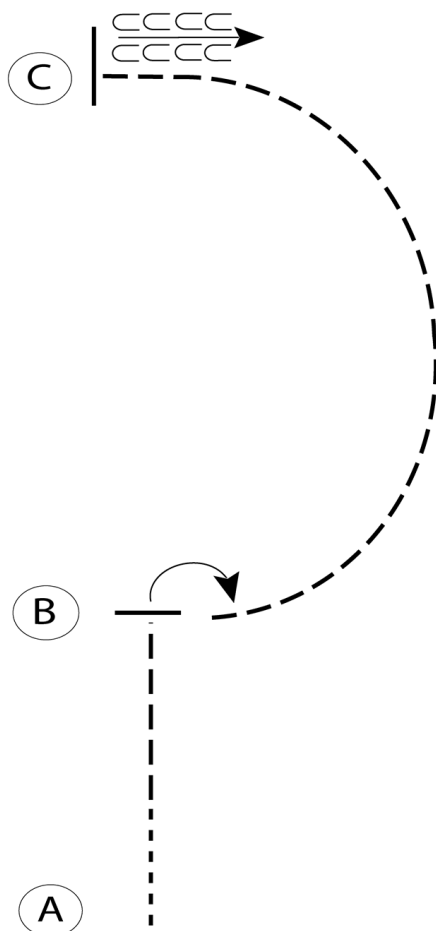

1. Be ready at A
2. Walk four steps from A.
3. Jog to B and stop.
4. Perform a 90 degree turn to the right on the hindquarters.
5. Jog a half circle to C.
6. At C stop and back four steps.

Walk	-----
Jog	- - - - -
Extended Jog	- - - - -
Lope	—————
Leg Yield	
Lead Change	— / —
Back	← ← ← ←
Marker	⊙ B
Sidepass	← — — — — →

[WH/WT-16]

Pattern Provided by:

The Judges

LEVEL I WESTERN RIDING PATTERN I

Sunday 9-1-24

LEGEND

.....	Walk
- - -	Jog
————	Lope
//////	Back
■	Lead Changing Area

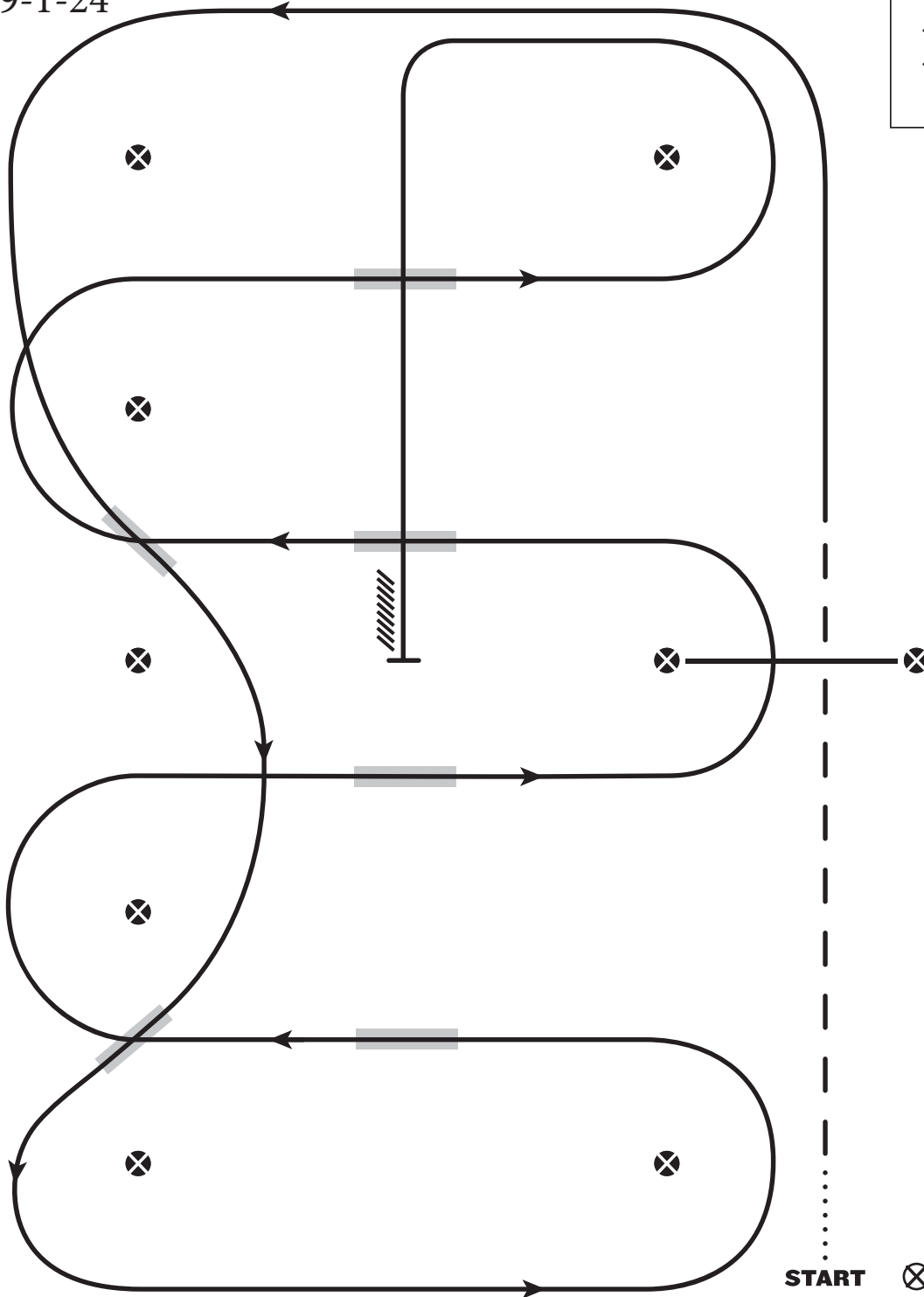

1. Walk at least 15 feet from start cone to the first marker, transition to jog, jog over log.
2. Transition to the lope left lead & lope around end
3. First line change
4. Second line change lope around the end of arena
5. First crossing change
6. Second crossing change
7. Lope over log
8. Third crossing change
9. Fourth crossing change
10. Lope up the center, stop & back

